



Center for Commercialization
of Fluorescence Technologies

Plasmonics in Fluorescence & Microscopy

Zygmunt (Karol) Gryczynsk



Center for Commercialization
of Fluorescence Technologies



**Center for Commercialization
of Fluorescence Technologies**
University of North Texas Health Science Center at Fort Worth, TX



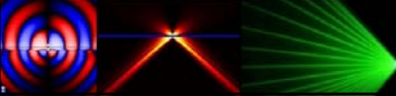

Department of Molecular Biology and Immunology, University of North Texas Health Science Center
350 Camp Bowie Blvd, Ft. Worth, TX 76107



Center for Commercialization
of Fluorescence Technologies



Center for Commercialization
of Fluorescence Technologies

Core Technologies/Research Focus



Center for Commercialization
of Fluorescence Technologies

Molecular and Cellular Fluorescence Time-Resolved Fluorescence/ FRET

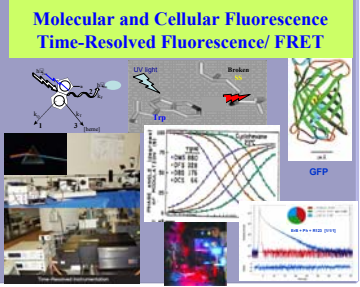

Nanotechnology Enhanced Sensing/Imaging

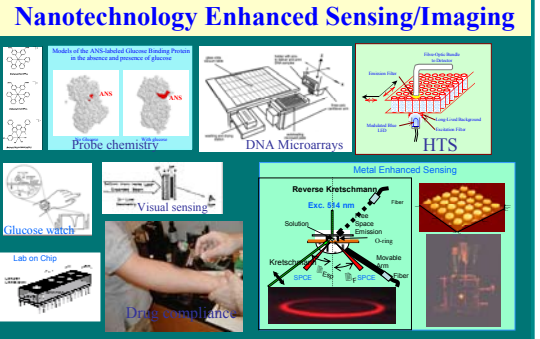

Multi-Photon Excitation Light Quenching

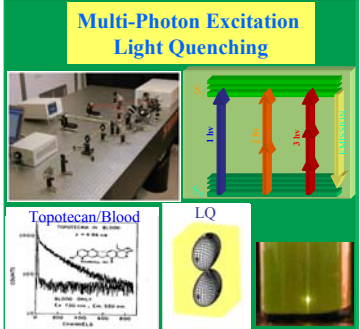

Advanced Microscopy, FLIM, SMD, SPAM, AFM

**Alba
MT 200**
With TIRF/SPCE attachments
Olympus TIRF
Custom TIRF Confocal Microscope

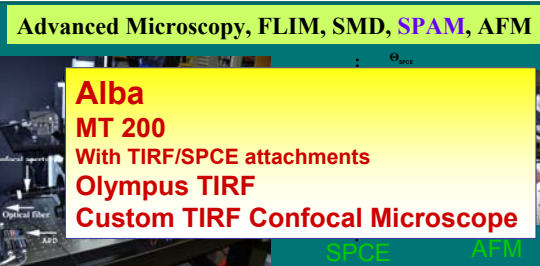

Recent Focus on Nanotechnology

1. Localized Surface Plasmons. Biomedical Applications of Metal Enhanced Fluorescence

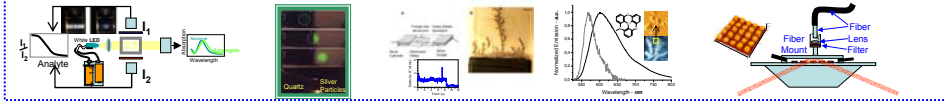

2. Traveling Surface Plasmons. Surface Plasmon Coupled Emission and Its Applications

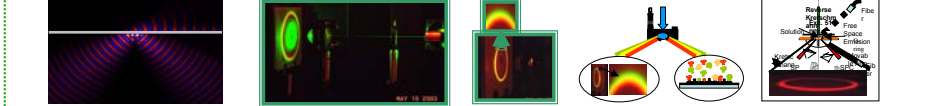

3. Surface Plasmon Assisted Microscopy (SPAM)

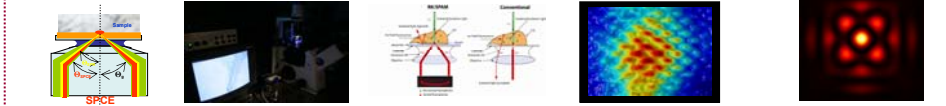

4. Rational Design of Plasmonic Nanostructures and Devices

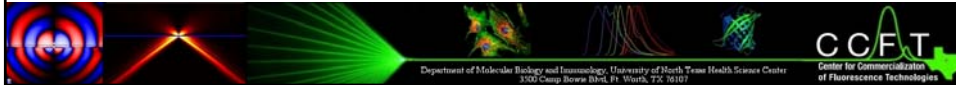

Modern Microscopy

- (1) Braking the Limits of Optical Resolution
- (2) Detection and Monitoring of Single Molecule

In the detection of single molecule background fluorescence is the biggest obstacle

- Stimulated emission depletion (STED) (Klar et al. 2000)
- Photo activated probes (proteins) (Betzig et al. 2006)
- Near-field scanning optical microscopy (NSOM) (de Lange et al. 2001)
- Zero-mode waveguide (Levene et al. 2003; Wenger et al. 2007)
- Confocal total internal reflection microscopy (Star & Thompson 2001; Thompson & Pero 2006)
- Surface plasmon-coupled emission (SPCE) (Borejdo et al. 2006) Including new approach based on standing SP (nnn et al. 2008)

What are the advantages of SPCE?

- Surface confined coupling
- Background suppression

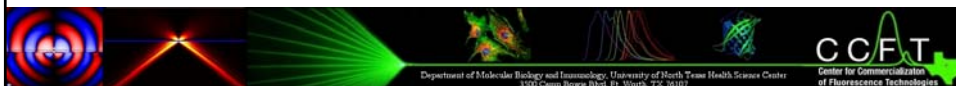
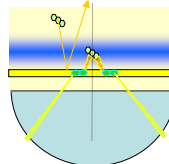

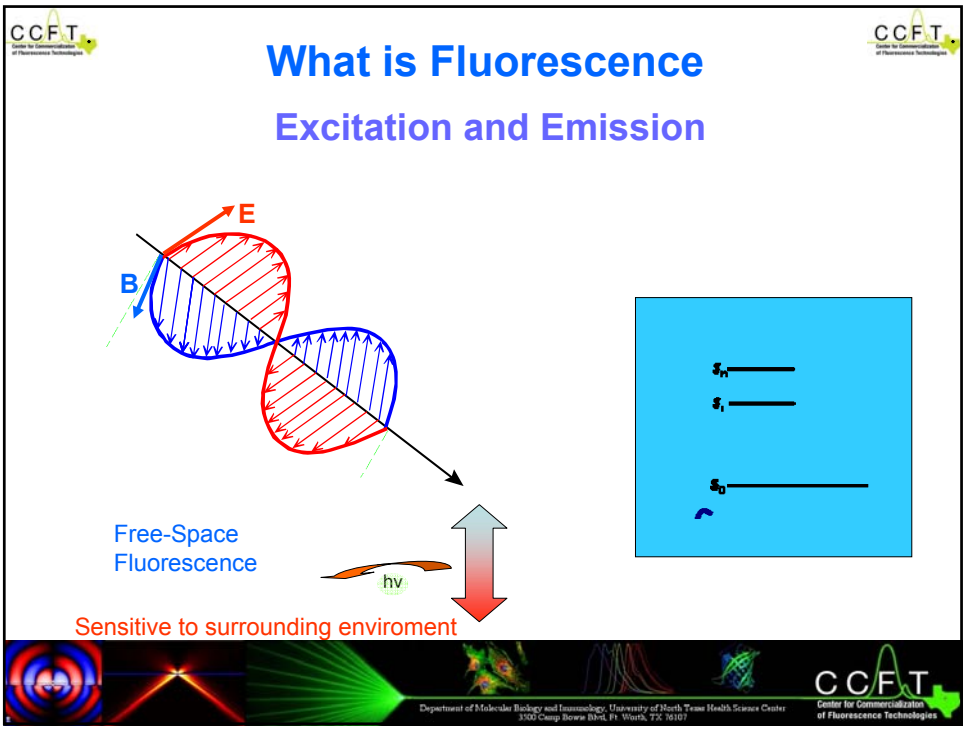
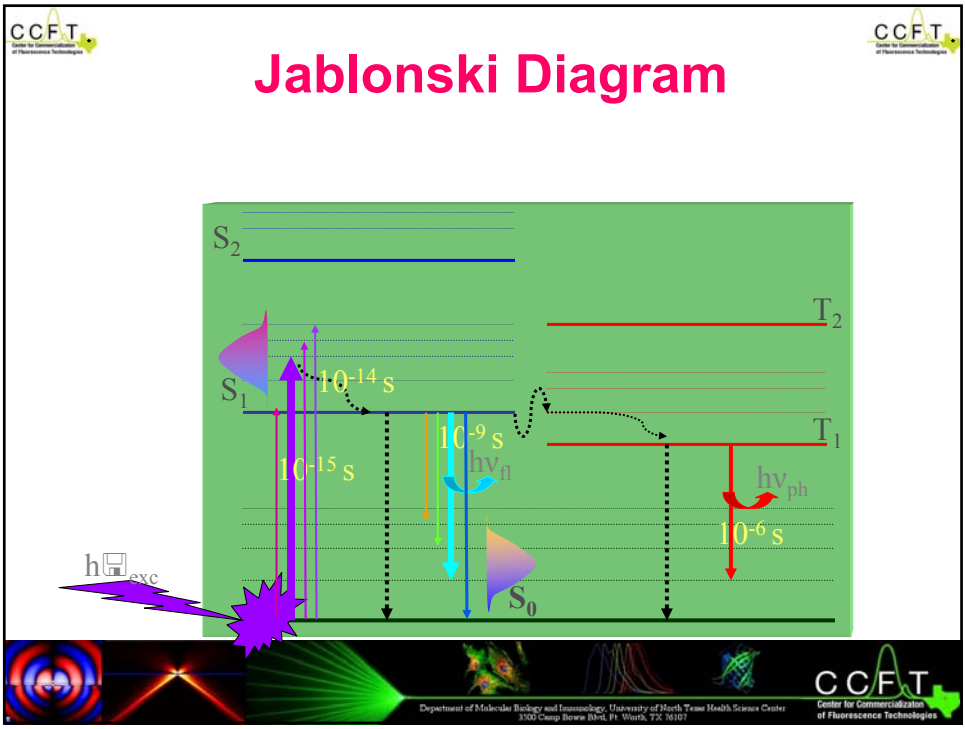

New Directions in Fluorescence Radiating Plasmons Model

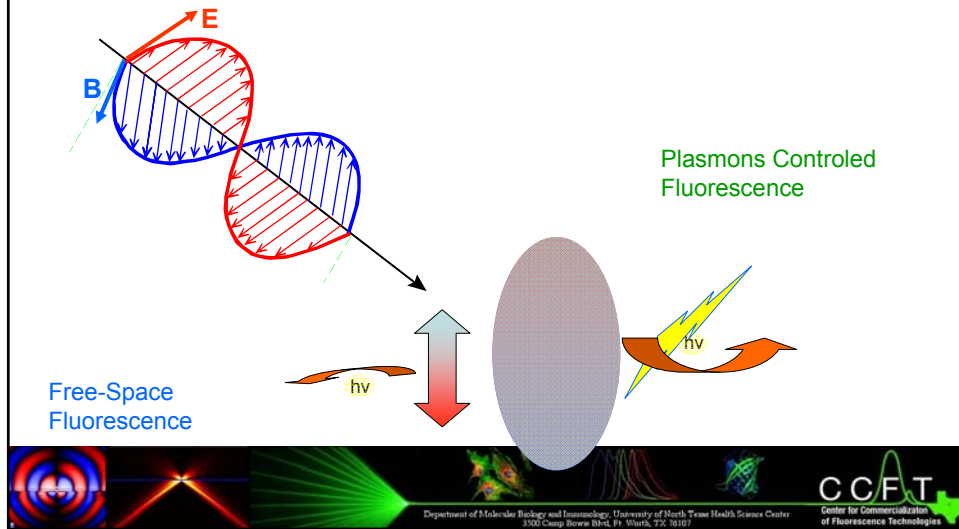

Optical Properties of Metal Colloids- Gold Colloidal Spheres

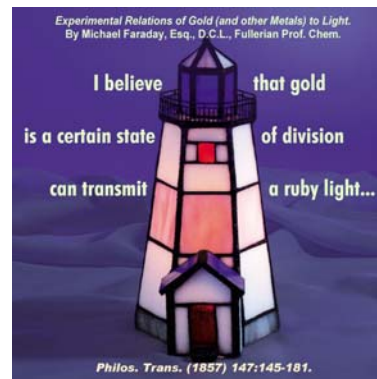
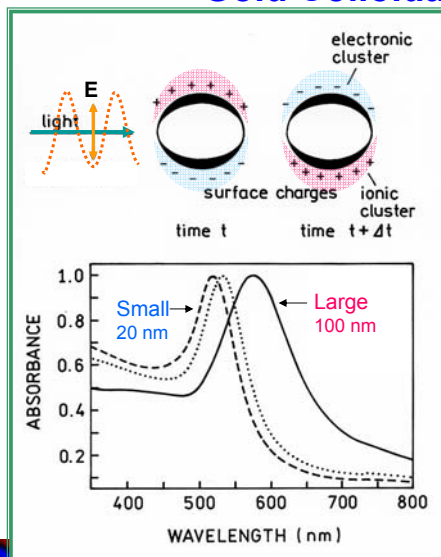

Can Intrinsic Particle Scattering Have Biomedical Applicability

Cell Labeling

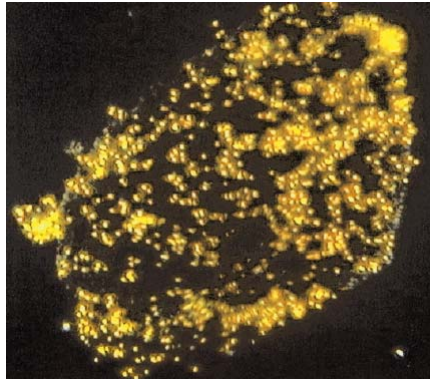

Photograph of epithelial buccal cells with 78-nm gold particles

J. Yguerabide and E. E. Yguerabide, *Anal. Biochem.* **262**, 137–156 (1998)

Different Plasmonic Phenomena

Localized Surface Plasmons

Travelling Surface Plasmons

Biomedical Applications of SP

Polarized Light Scattering of Particles

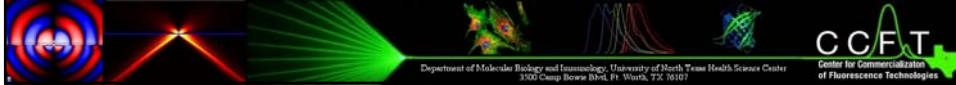
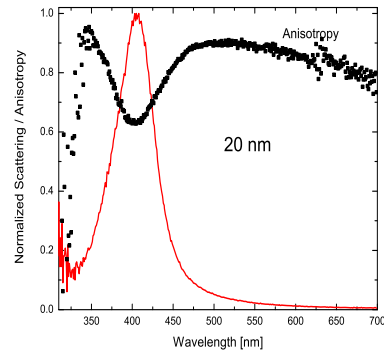
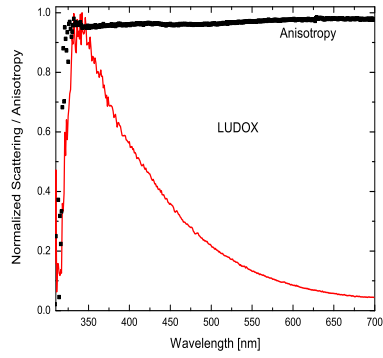
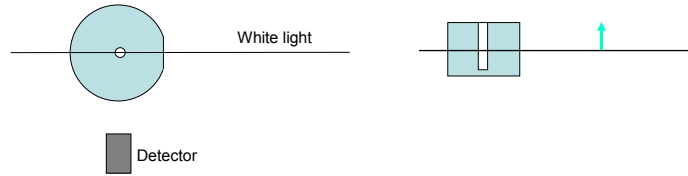

Different Colloids Concentrations

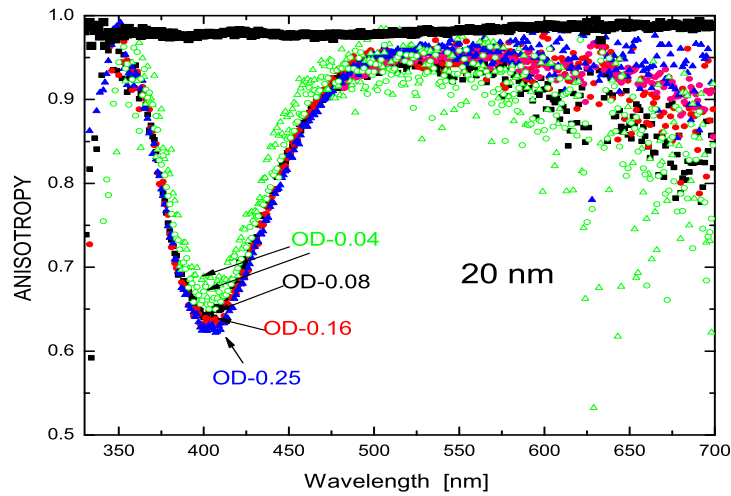

What About Wavelength or Solvent Viscosity

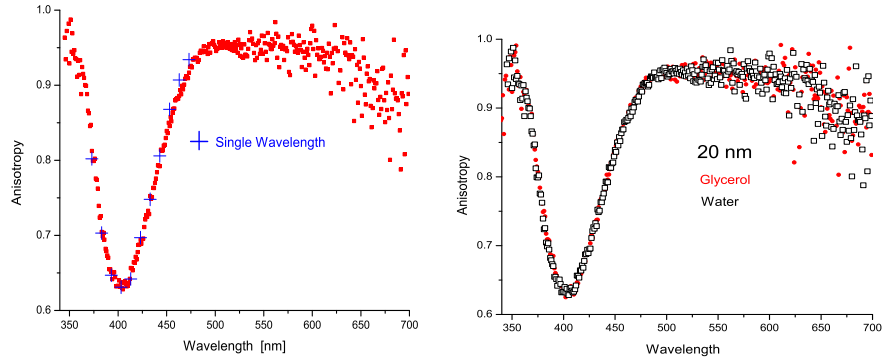

Application of Polarization Dependent Colloid Scattering

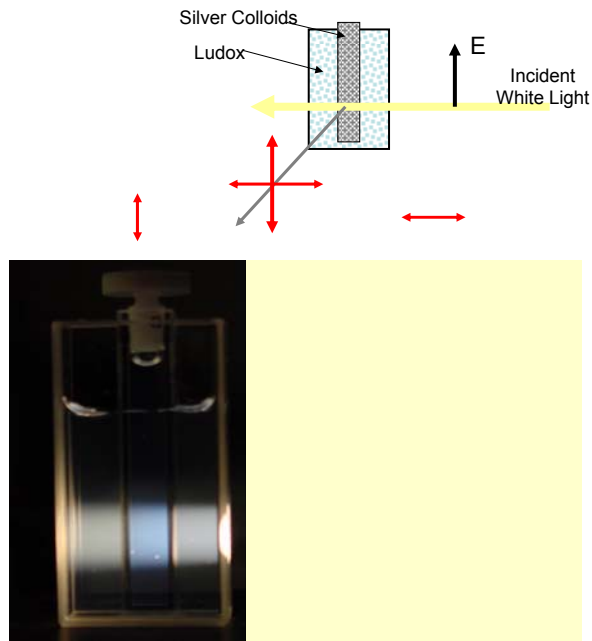

How to Explain Polarization Effect?

Polarization of a prolate spheroid in a uniform electric field

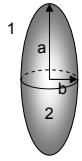

$$\begin{cases} x = f\sqrt{\xi^2 - 1}\sqrt{1 - \eta^2} \cos(\varphi) \\ y = f\sqrt{\xi^2 - 1}\sqrt{1 - \eta^2} \sin(\varphi) \\ z = f\xi\eta \end{cases}$$

$$\begin{cases} \xi > 0 \\ 0 \leq \eta < 1 \\ 0 \leq \varphi < 2\pi \end{cases}$$

Laplace' equation of a potential V

$$\begin{cases} \nabla^2 V = 0 \\ V = \sum_{n=0}^{\infty} \sum_{m=-n}^n [A_n^m P_n^m(\xi) + B_n^m Q_n^m(\xi)] P_n^m(\eta) e^{im\varphi} \end{cases}$$

polarizabilities along the long and short axes

$$\alpha = f^3 \frac{4\pi\epsilon_1(\epsilon_1 - \epsilon_2)\xi_0}{3[\epsilon_1\xi_0 Q_1'(\xi_0) - \epsilon_2 Q_1(\xi_0)]} \quad \beta = f^3 \frac{8\pi\epsilon_1(\epsilon_2 - \epsilon_1)\xi_0\sqrt{\xi_0^2 - 1}}{3[\epsilon_1(\xi_0^2 - 1)Q_1'(\xi_0) - \epsilon_2\xi_0 Q_1'(\xi_0)]}$$

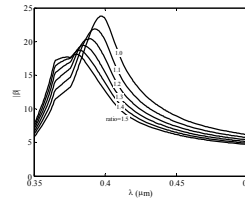
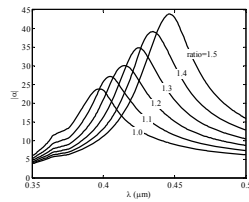

Interference of surface plasmon resonances causes enhanced depolarized light scattering from metal nanoparticles. (2007) Calander, N., Gryczynski, I., Gryczynski, Z. *Chem. Phys. Lett.* **434**, 326-330.

Depolarized light scattering from silver nanoparticles. Gryczynski, Z., Lukomska, J., Lakowicz, J.R., Matveeva, E.G., Gryczynski, I. (2006) *Chem. Phys. Lett.* **421**, 189-192.

Phase difference of two resonances may exceed 90° in between, if they are enough far apart

The two components are in phase – resultant mainly in the direction of the electric field

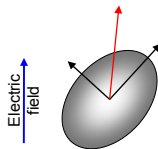

The two components are out of phase – resultant more perpendicular to the electric field

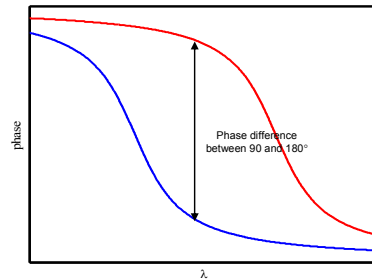
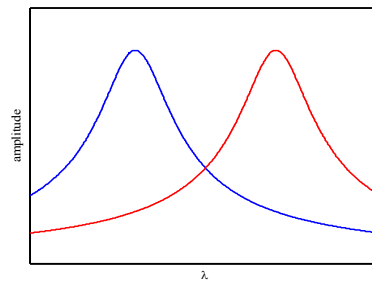
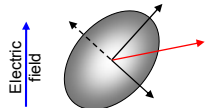

Estimating Scattering from Shape Distribution

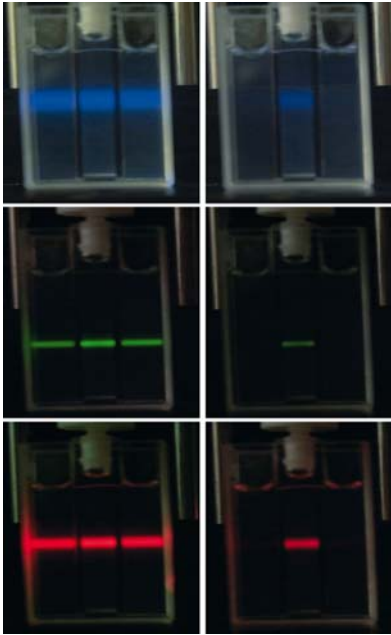
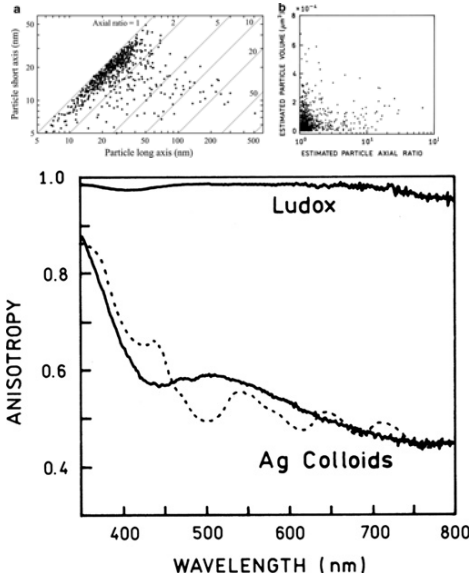
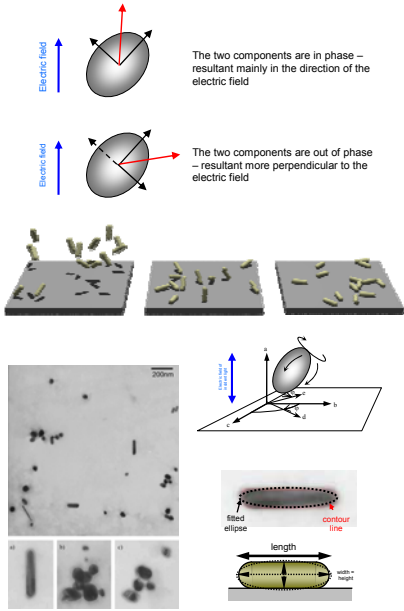

Wavelength-Ratiometric Scattering Sensor Based on Metallic Colloids

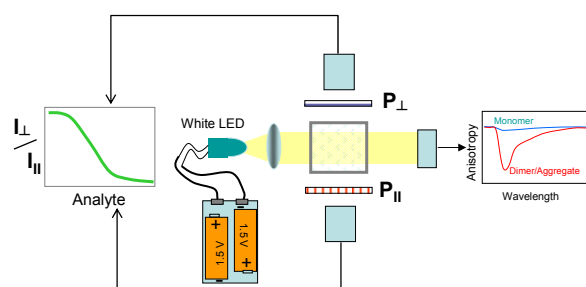
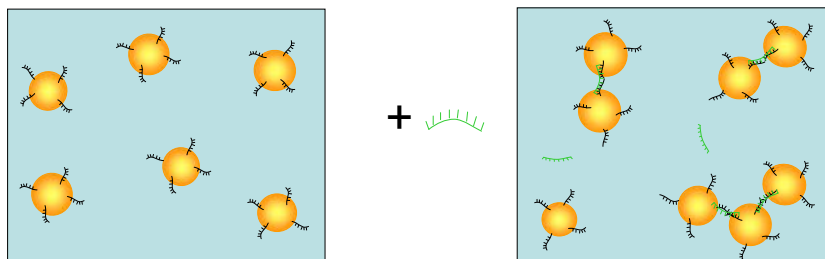

Metal Enhanced Fluorescence (MEF)

Metal Enhanced Fluorescence – Localized Plasmons

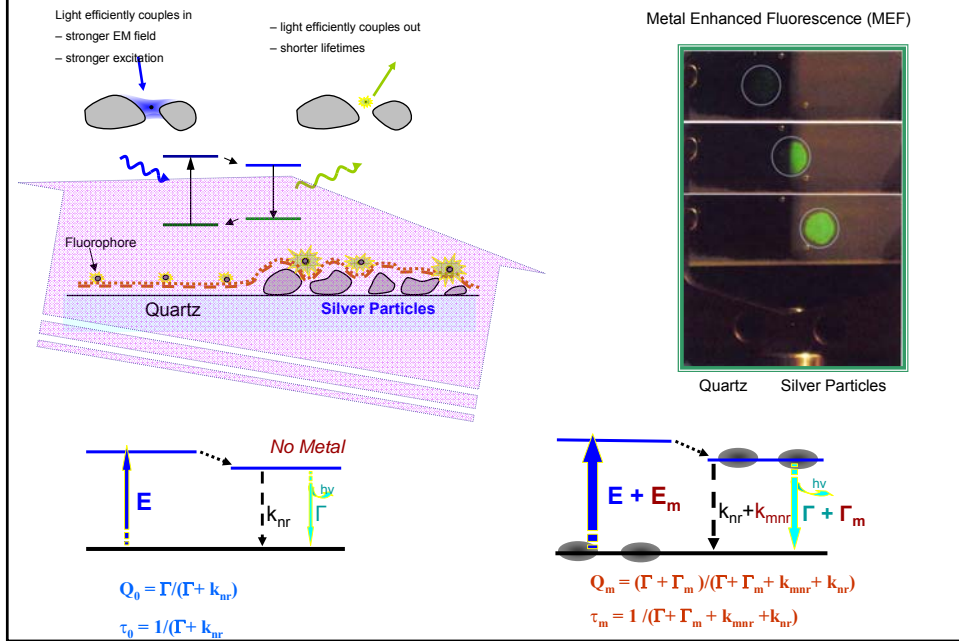

Metallic Surfaces can Create Unique Fluorophores with High Quantum Yields and Short Lifetimes

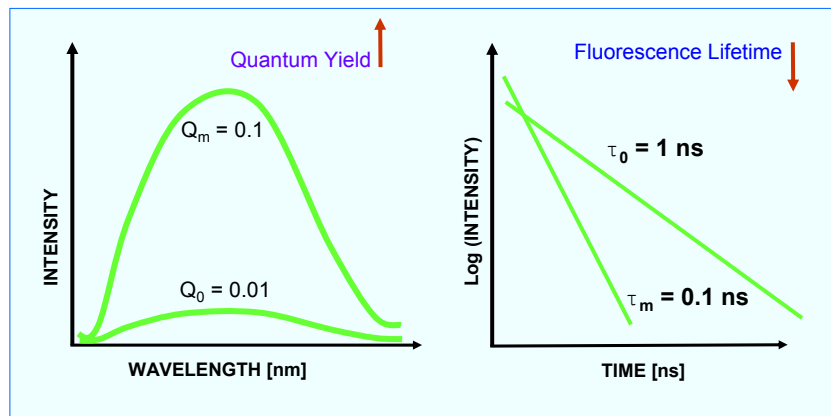

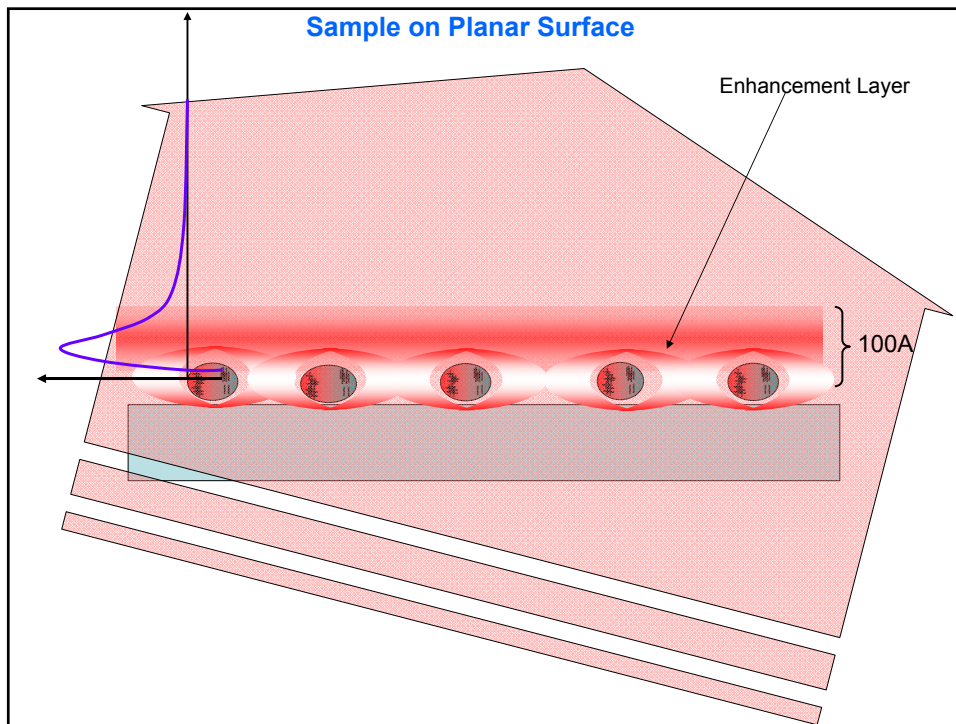

Fluorescence Immunoassays with Non-Fluorescent Chromophores

An = Analyte
Ab = Antibody

The schematic shows a surface with Y-shaped antibodies (Ab) attached. Some are bound to a green circle labeled "An" (Analyte). A yellow rectangular region labeled "enhancement region" is shown above the surface, with a green circle labeled "F" inside it. A blue vertical line next to the enhancement region is labeled "~100 Å".

The top image is a fluorescence microscopy image showing a grid of bright spots. A color scale on the right ranges from 0.0 to 80.0. The bottom image is a line scan showing intensity peaks corresponding to the spots in the image above. The x-axis is labeled "0 5 10 μm" and the y-axis is labeled "100 200 300".

- Easy preparation
- Difficult to control

Intrinsic Emission from Unlabeled DNA

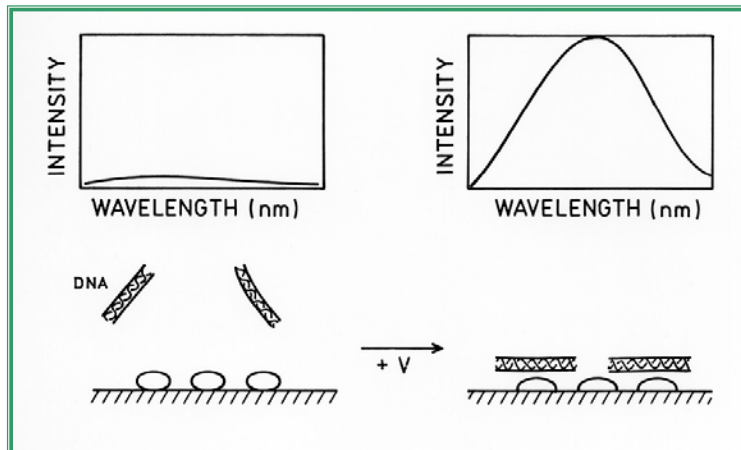

Emission Spectra of Double Helical DNA in the Presence and Absence of Silver Island Films

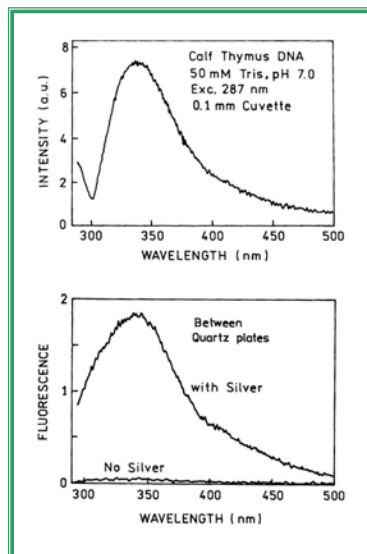

Frequency-Domain Intensity Decays of Double Helical DNA in the Absence and Presence of a Silver Island Film

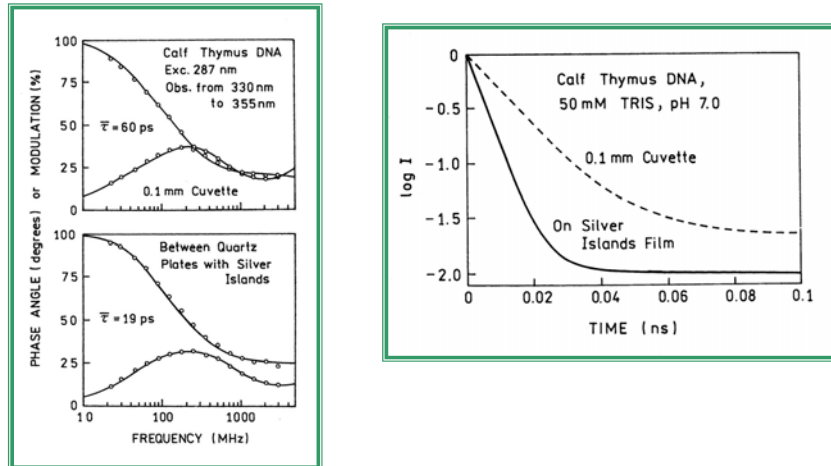

How Enhancement Depends on Distance ?

How to experimentally measure enhancement?

Distance Dependence of Enhanced Fluorescence of Cy3 and Cy5-Labeled Oligonucleotides

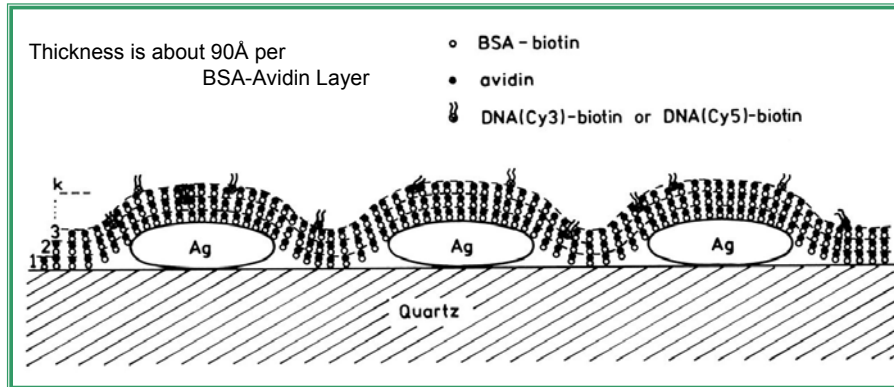

Absorption Spectra Show Complete Coverage for Each BSA-Biotin-Avidin Layer

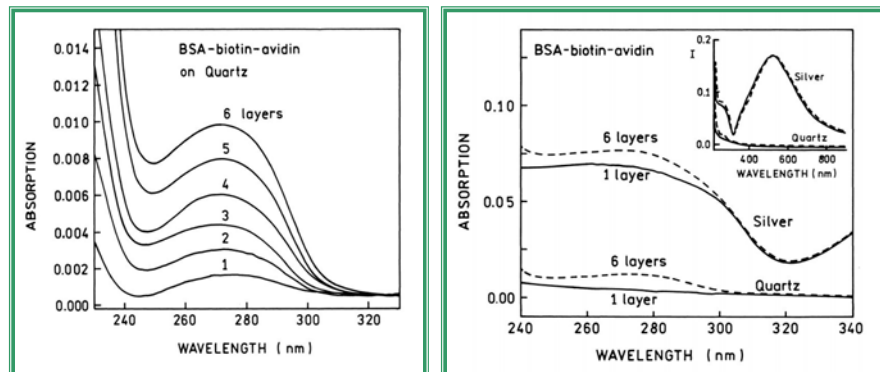

Dependence of Emission Intensity on Distance from Silver Particles

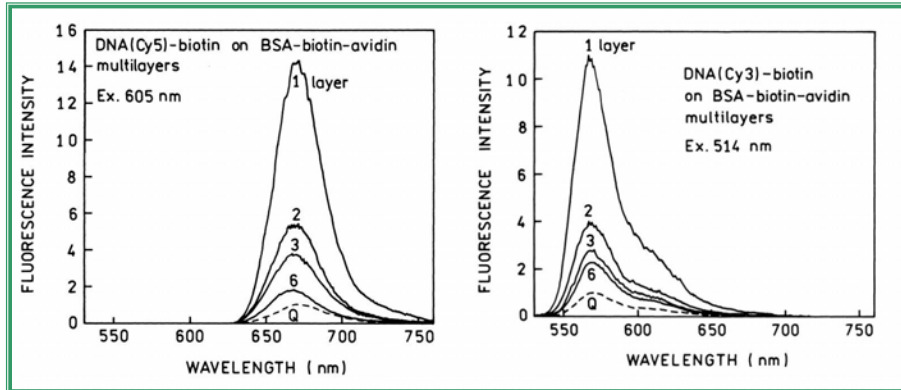

Shortest Lifetimes are Found for the Shortest Distance with BSA-Biotin-Avidin Layer

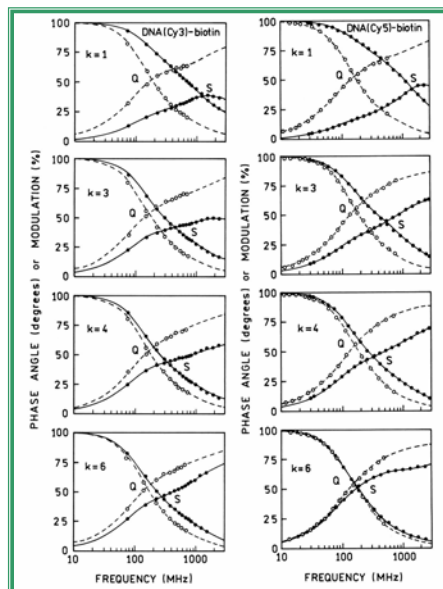

Relative Intensity and Lifetimes of DNA(Cy-dyes) on Quartz and SIFs

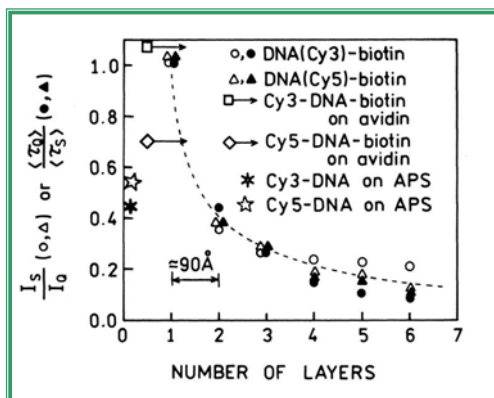
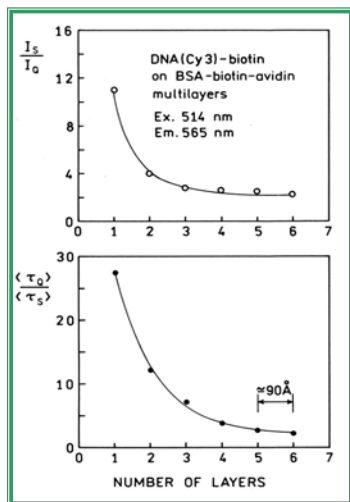

Model

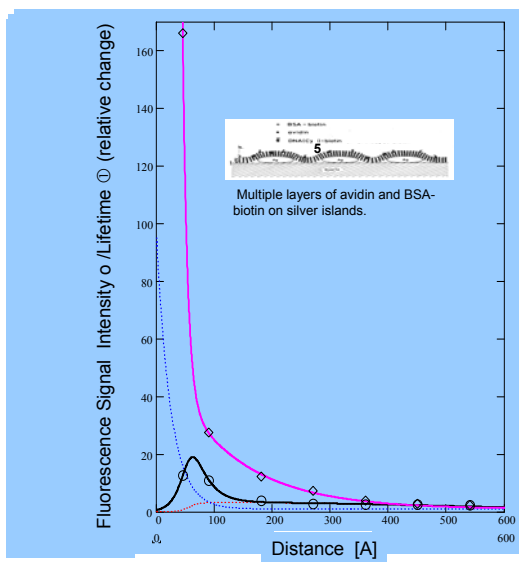
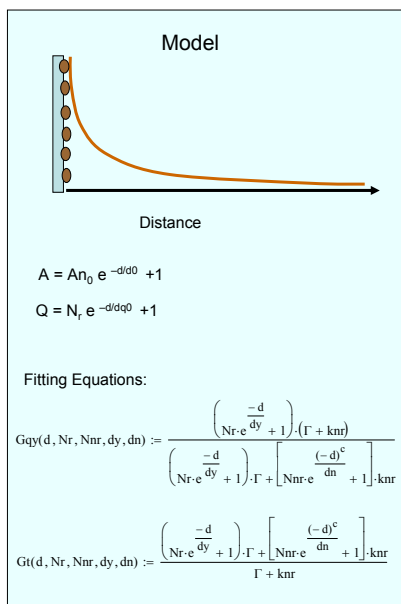

Distance Dependence of Excitation (ex) Radiation (r) and Non-Radiative (ns) Decay

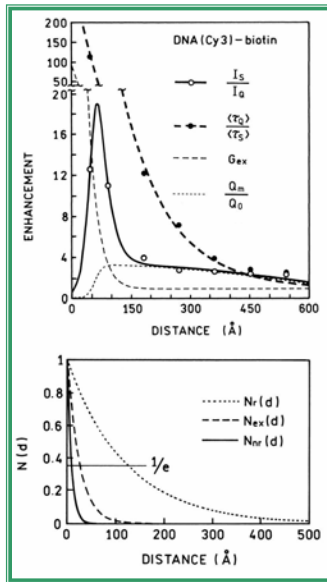

Fluorescent Properties Near Metal Particle

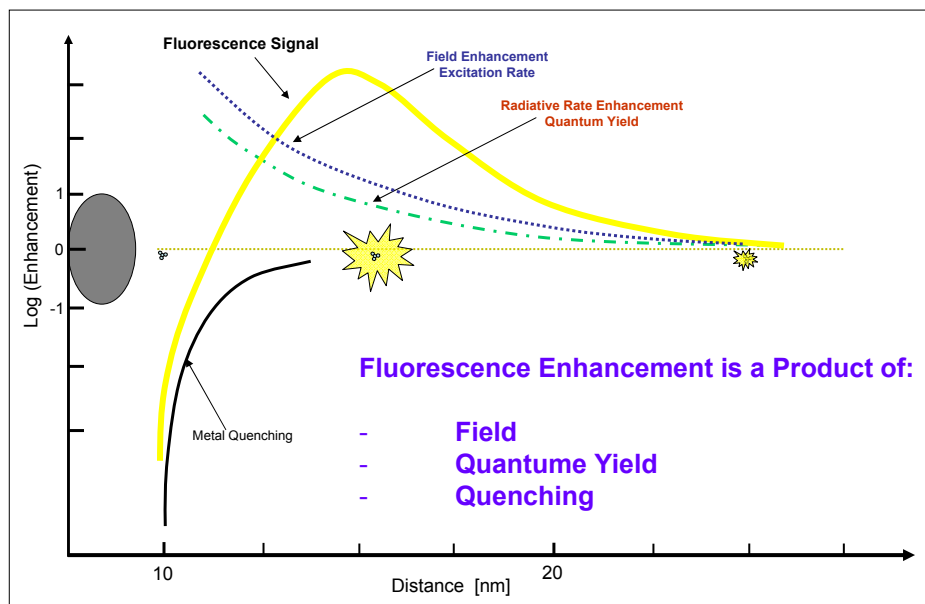

Fluorescence Enhancement is a Product of:

- Field
- Quantum Yield
- Quenching

How to separate field enhancement and quantum yield enhancement?

Use non-linear process like $2h\nu$
Or
Observe only single molecule

Multi-Photon Excitation - Ultra Bright Fluorophores

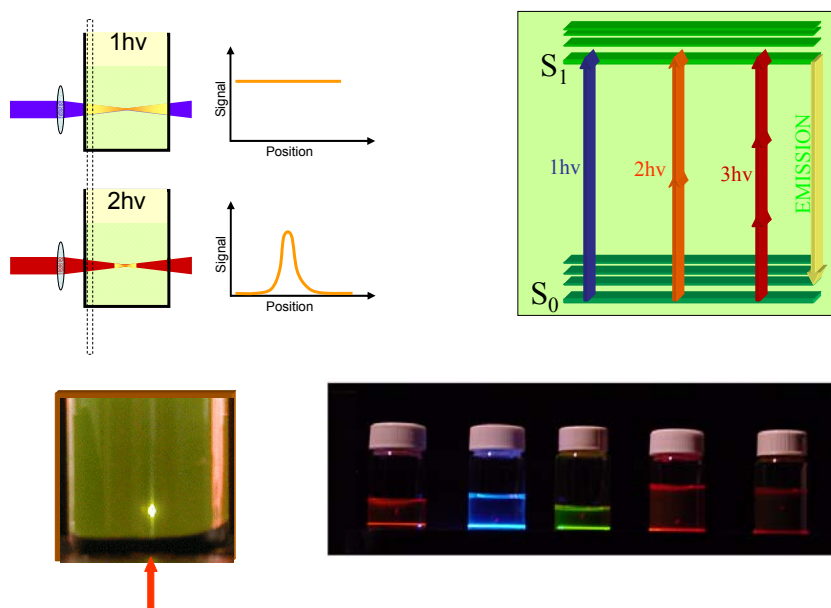



$$Q = \frac{\Gamma_r}{\Gamma_r + \Gamma_{nr}} \quad \tau = \frac{1}{\Gamma_r + \Gamma_{nr}}$$

$$Q_m = \frac{N_r \Gamma_r}{N_r \Gamma_r + N_n \Gamma_{nr}} \quad \tau_m = \frac{1}{N_r \Gamma_r + N_n \Gamma_{nr}}$$

$$G_{sp} = \frac{Q_m}{Q} = \frac{N_r (\Gamma_r + \Gamma_{nr})}{N_r \Gamma_r + N_n \Gamma_{nr}} \quad G_r = \frac{\tau_m}{\tau} = \frac{\Gamma_r + \Gamma_{nr}}{N_r \Gamma_r + N_n \Gamma_{nr}}$$

$$G_{\beta}^{(1)} = G_{exc} \cdot G_{em} = G_{exc} N_r \frac{\tau_m}{\tau} \quad G_{\beta}^{(2)} = G_{exc}^2 \cdot G_{em} = G_{exc}^2 N_r \frac{\tau_m}{\tau}$$

$$\frac{G_{\beta}^{(2)}}{G_{\beta}^{(1)}} = G_{exc}$$

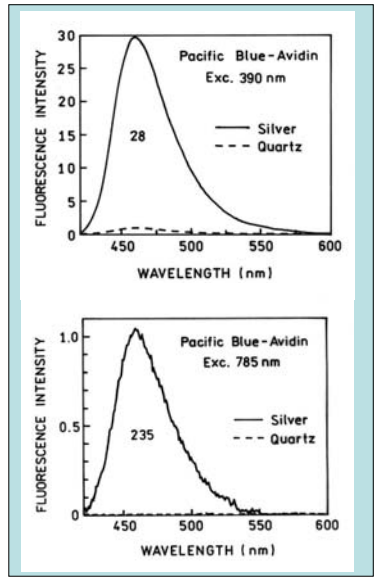

Table. Calculated enhancement factor for the labeled avidin

Probe	$G_{\beta}^{(1)}$	$G_{\beta}^{(2)}$	G_{exc}	Γ (ns ⁻¹) ^b	Γ_m (ns ⁻¹) ^b	N_r
Pacific Blue	28	235	25	0.32	11 ^c	35
Lissamine	16	200 ^a	9.5 ^a	0.53	23 ^c	45
Texas Red	46	200 ^a	418 ^a	0.16	71 ^c	455

^aCalculated assuming two-photon excitation displays a 200-fold increases in probe fluorescence on the silver island films.
^bCalculated using $\Gamma = Q/\langle\tau\rangle$
^cCalculated assuming the quantum yield $Q = 1.0$ on the silver island films

Conclusion
Picosecond Laser Diode Can Be Used for Two-Photon Excitation

Fluorescence properties of labeled proteins near silver colloid surfaces (2003). Maliwal B.P., Malicka J., Gryczynski I., Gryczynski Z., Lakowicz J.R., Biopolymers (Biospectroscopy), 70, 585-594.

Is the enhancement real or could it be a concentration artifact?

How to design experiment where the signal will NOT depend on dye deposition?

Application of MEF to Muscle Study

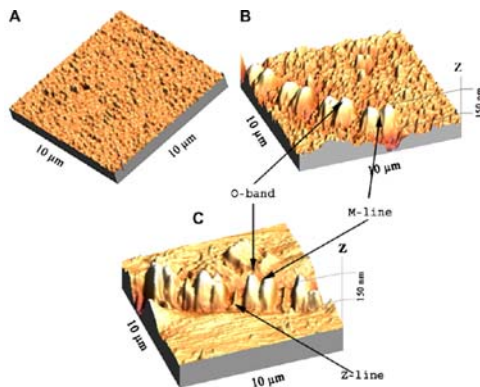

- (A) AFM image of glass coated with SIF
- (B) myofibrils on glass coverslips coated with SIF
- (C) myofibrils on glass coverslips

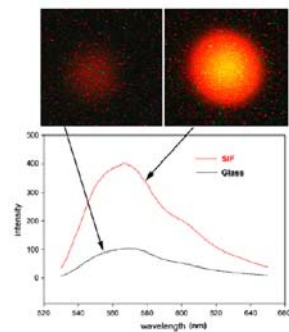

Enhancement of fluorescence by SIF. Myofibrils (1 mg/mL) labeled with 0.1 μ M Rh-phalloidin were placed on a glass coverslip (top left) and on a coverslip coated with SIF (top right). The spectra were measured at a 45 angle in a Varian Eclipse spectrofluorometer. The vertical scale is in arbitrary units (a.u.). The spectrum of SIF in the absence of muscle is less than 10 a.u. at all wavelengths.

Increased Brightness on SIFs

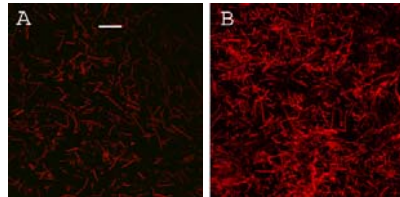

Confocal image of myofibrils contributing to the fluorescence of

- (A) myofibrils on glass coverslip;
- (B) myofibrils on glass covered with SIF. Bar is 10 μ m. Exposure is the same in each panel.

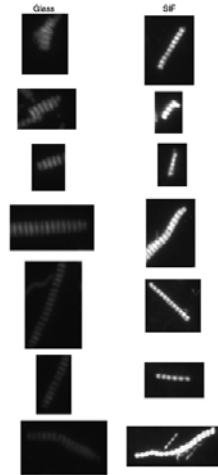

Enhancement of fluorescence by SIF using TIRF fluorescence. Myofibrils were placed on glass coverslip (left column) or on glass coverslips coated with SIF and detected by TIRF. The representative images, from the faintest to the most intense, are shown. Exposure times and camera gain are the same for each panel.

Decreasing Photobleaching by Silver Island Films: Application to Muscle

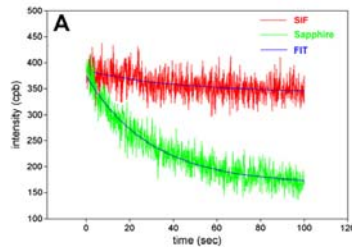
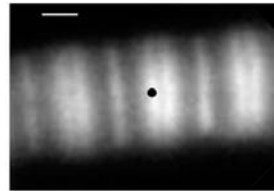

Comparison of the rate of photobleaching of the myofibrillar overlap zone on uncoated sapphire (green) and on sapphire coated with SIF (red)

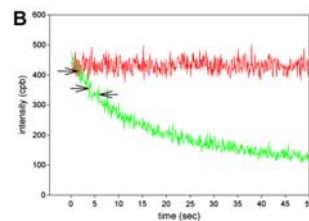
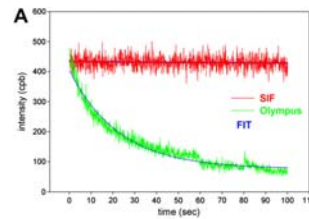

Comparison of the photobleaching of myofibrillar overlap zone on uncoated Olympus TIRF coverslips (green) and on Olympus TIRF coverslips coated with SIF (red)

Anal. Biochem. (2007) **366**, 228-236

Biomedical Applications of Localized Plasmons

Fluorescence Assays Utilizing MEF

HTS Format Assay

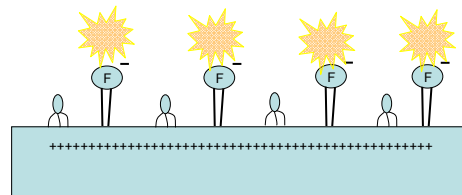
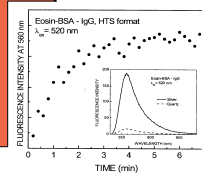
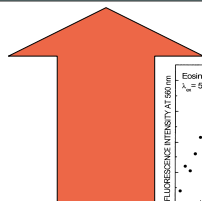
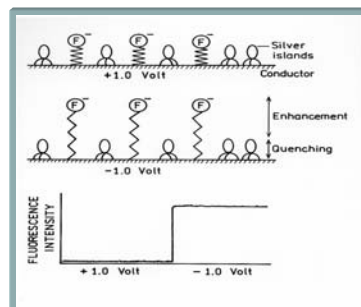
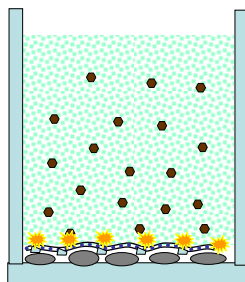

DNA Hybridization Can be Measured Using Silver – Enhanced Fluorescence

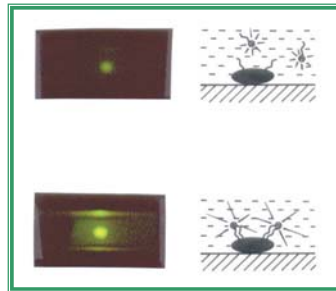
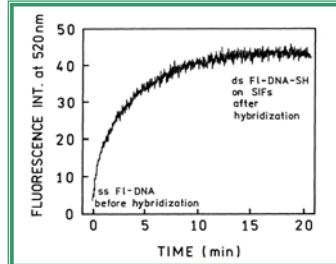
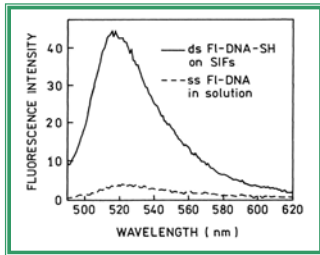
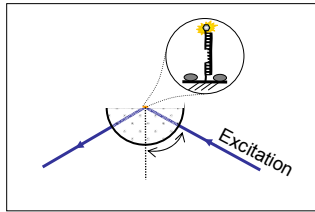

Use of surface plasmon-coupled emission to measure DNA hybridization (2004). Malicka J., Gryczynski I., Gryczynski Z., Lakowicz J.R., *J. Biomol. Screening*, **9**(3), 208-215.

TIRF Immunoassay on a Silver Island Surface

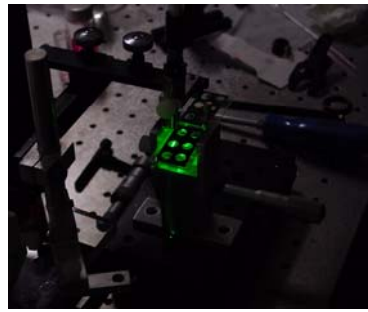
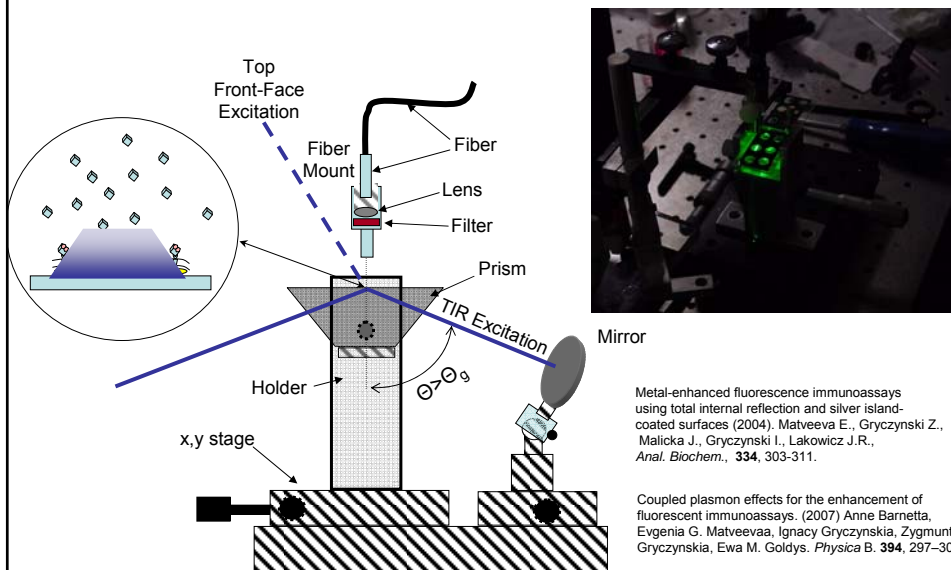

Metal-enhanced fluorescence immunoassays using total internal reflection and silver island-coated surfaces (2004). Matveeva E., Gryczynski Z., Malicka J., Gryczynski I., Lakowicz J.R., *Anal. Biochem.*, **334**, 303-311.

Coupled plasmon effects for the enhancement of fluorescent immunoassays. (2007) Anne Barnetta, Evgenia G. Matveeva, Ignacy Gryczynska, Zygmunt Gryczynska, Ewa M. Goldys. *Physica B*. **394**, 297-300.

Scanning Confocal System. Capability of Separating 500 nm Spots

What maximum enhancement to expect ?
Can We Do Immunoassay on a Single Molecule Level ?

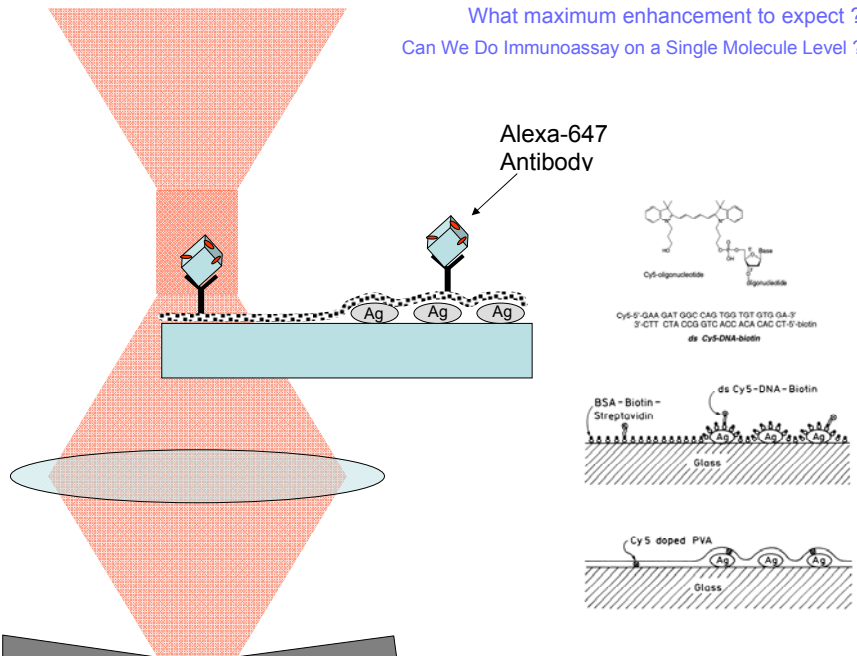

Monolayer of Labeled Antibodies

On Glass
(Intensity Scale 0-10)

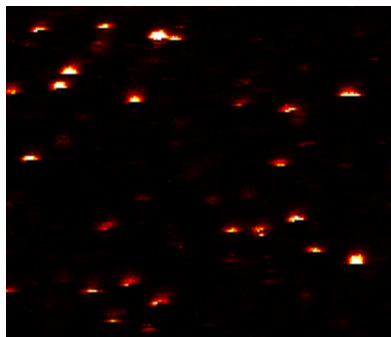

On Silver Island Film
(Intensity Scale 0-100)

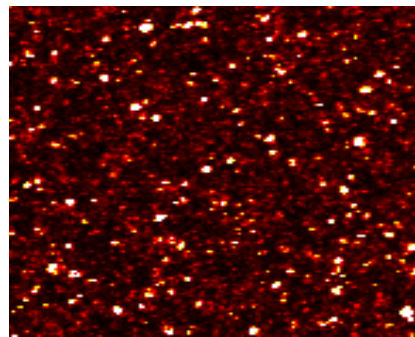

Future of Biomedical Assays – Assay Based on Single Molecule

Alexa647 c=1pg/ml **GLASS** $\lambda=635\text{nm}$ Filter HQ685nm/70

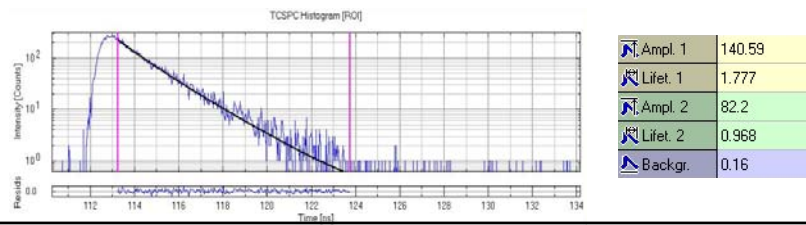
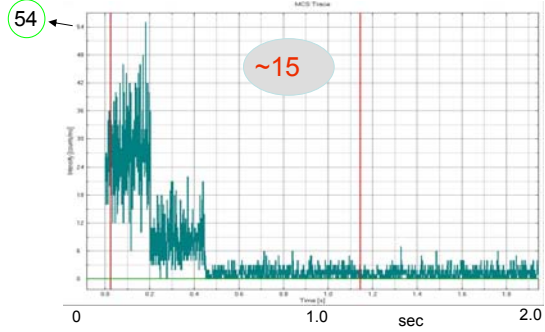
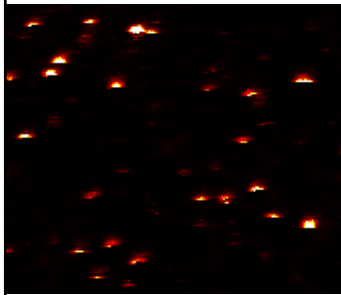

Alexa647 c=1pg/ml **SILVER** $\lambda=635\text{nm}$ Filter HQ685nm/70

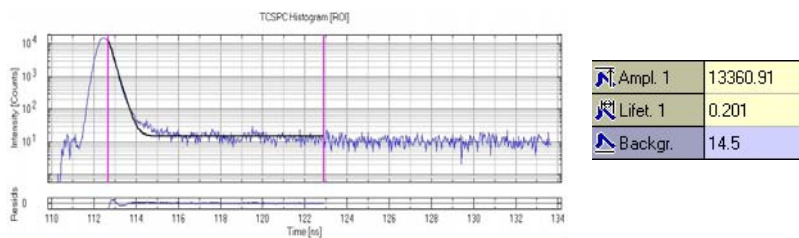
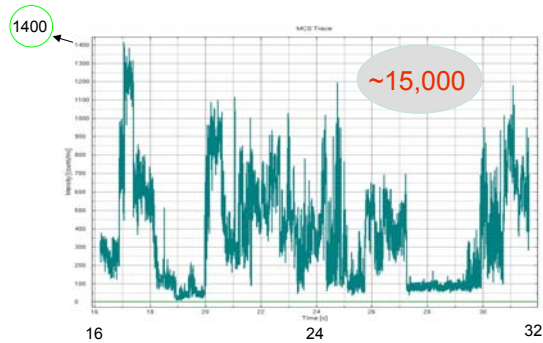
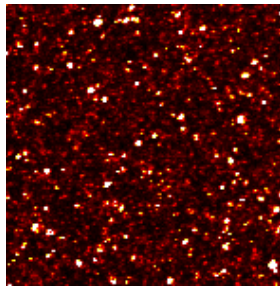

Assay Based on Nanostructures and Microfluidics

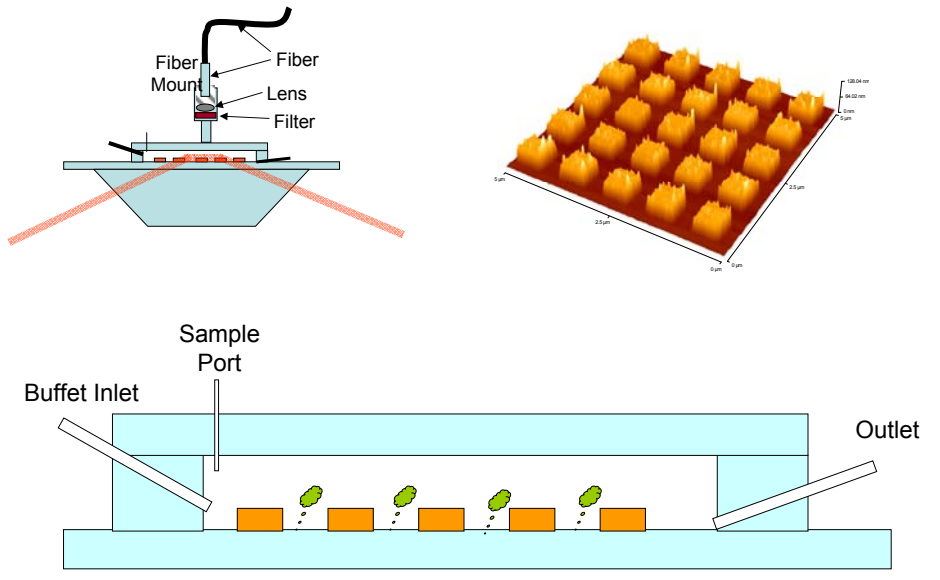

Can we improve enhancement?

New Structures

New Structures

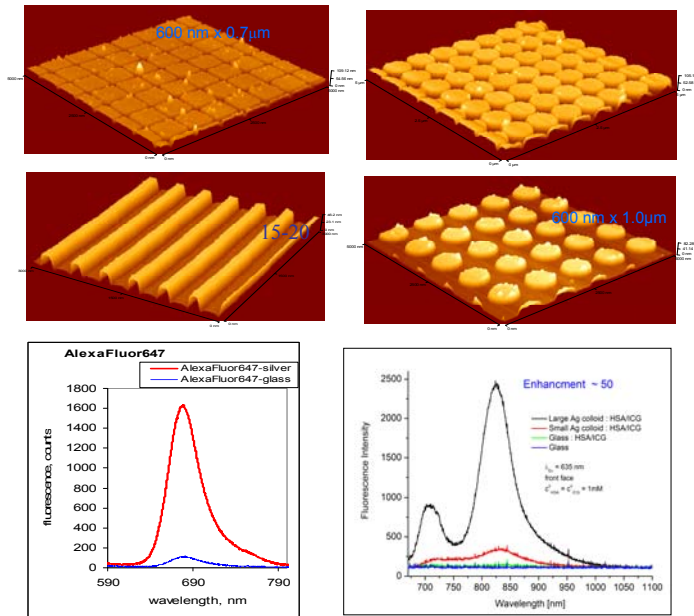

New Structures

Fluorescence Enhancement on Silver Fractal-Like Structures

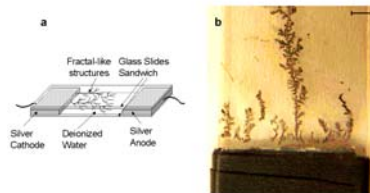

- a) The sandwich set-up for electrochemical growth of silver fractal-like structures on glass slides.
- b) The photo of the glass slide with grown silver fractal-like structures. The bar on top is 6 mm in length.

The fluorescence intensities due to the immunoassay measured at the cross-section of the glass slide with fractal-like structures shown in Figure a as a white line.

The fluorescence intensities due to the immunoassay measured at the cross-section of the clean glass slide shown in Figure c as a white line.

The fluorescence intensities due to non-specific binding measured at the cross-section of the glass slide with fractal

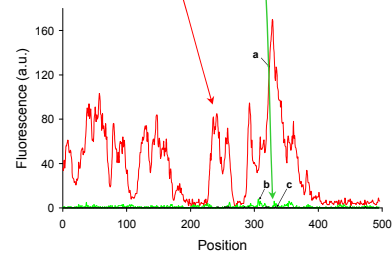
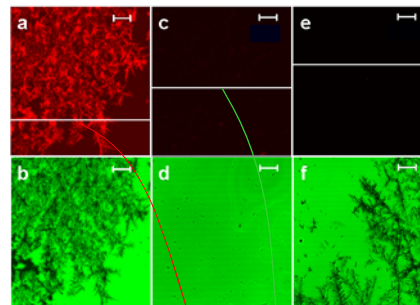

JACS (2007) 129, 12117-12122
Anal. Biochem. (2008) 80 (6), 1962-1966

New Structures

Fluorescence Enhancement on Silver Fractal-Like Structures

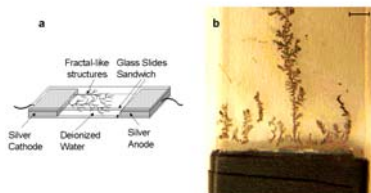

a) The sandwich set-up for electrochemical growth of silver fractal-like structures on glass slides.

b) The photo of the glass slide with grown silver fractal-like structures. The bar on top is 6 mm in length.

The fluorescence intensities due to the immunoassay measured at the cross-section of the glass slide with fractal-like structures shown in Figure a as a white line.

The fluorescence intensities due to the immunoassay measured at the cross-section of the clean glass slide shown in Figure c as a white line.

The fluorescence intensities due to non-specific binding measured at the cross-section of the glass slide with fractal

JACS (2007) **129**, 12117-12122
Anal. Biochem. (2008) **80** (6), 1962-1966

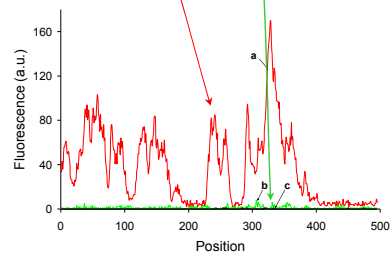
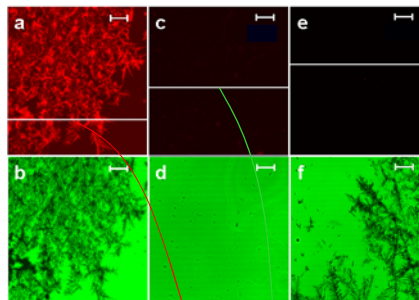

What could be better now?

FRACTALS / GOLD MIRROR

Model Immunoassay

The enhancement can be ~1000 fold

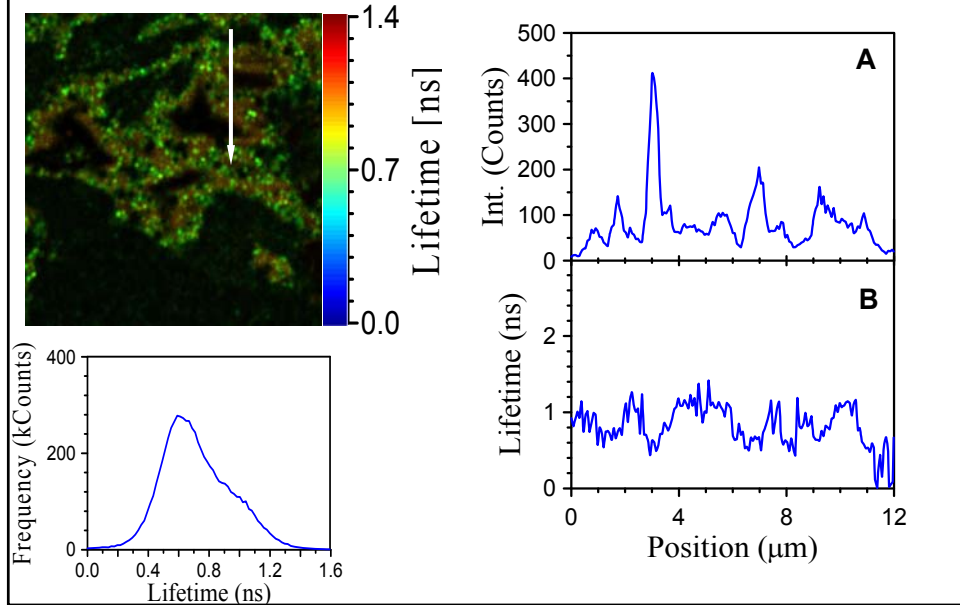

SM on FRACTALS

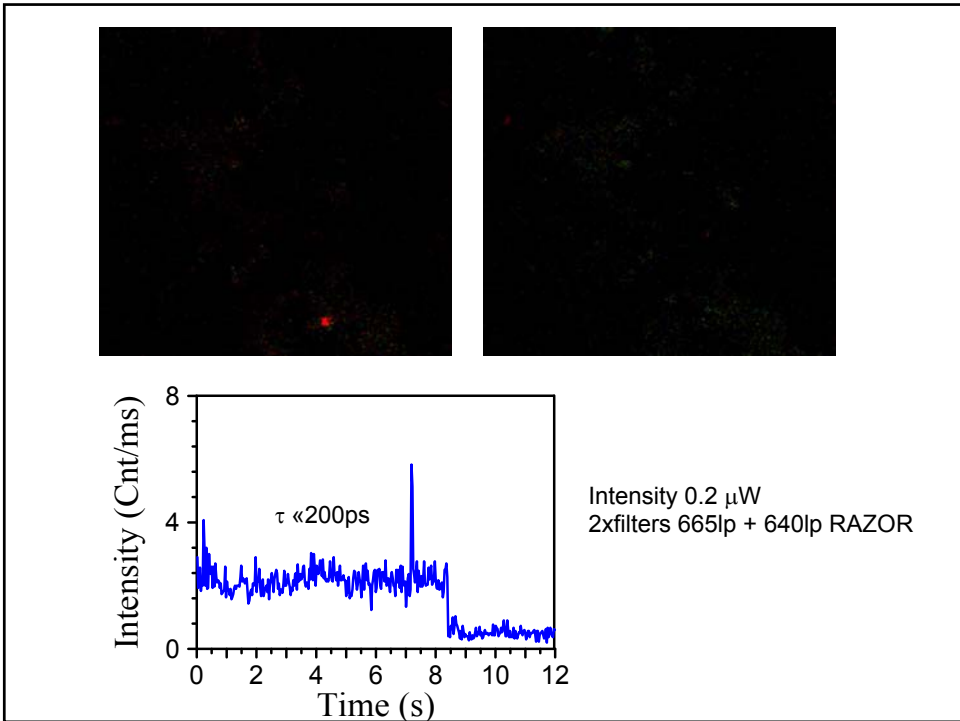
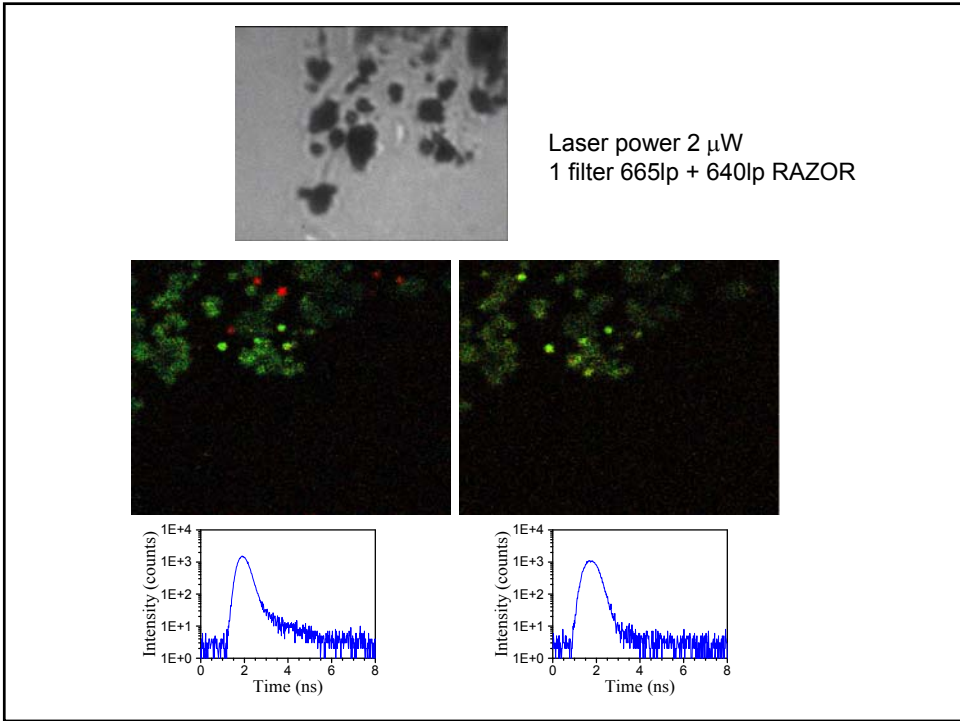

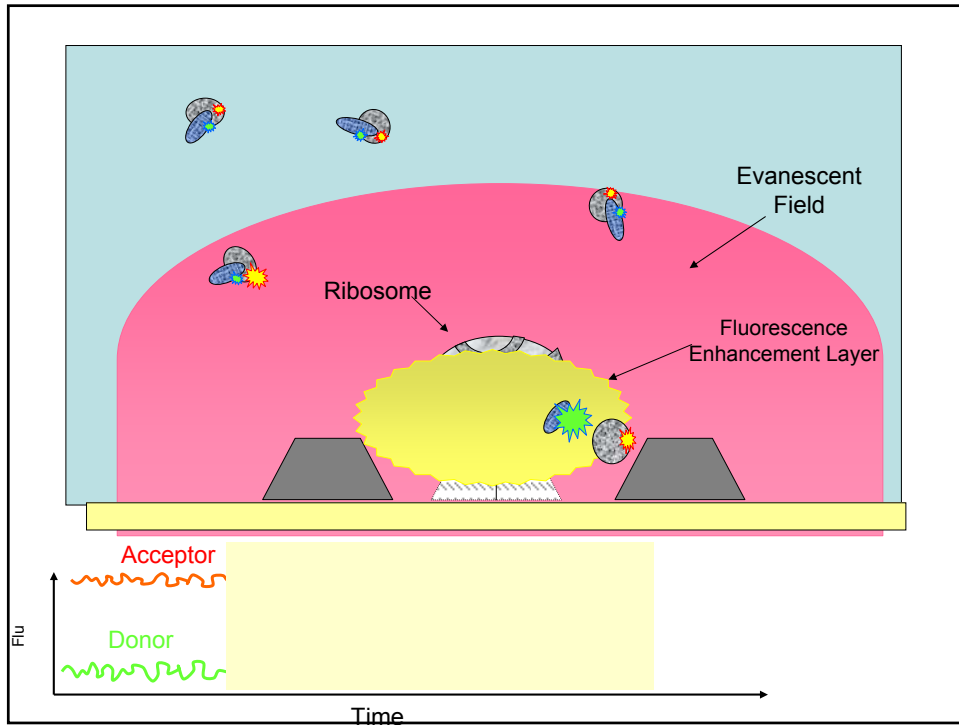

Traveling Surface Plasmons

SPCE
New Concept of Fluorescence

• Fluorophore emits in random directions

Wavelength resolution of SPCE

CCFT
Center for Commercialization of Fluorescence Technologies

Department of Molecular Biology and Immunology, University of North Texas Health Science Center
3500 Camp Bowie Blvd, Ft. Worth, TX 76107

Surface Plasmons

CCFT
Center for Commercialization of Fluorescence Technologies

Department of Molecular Biology and Immunology, University of North Texas Health Science Center
3500 Camp Bowie Blvd, Ft. Worth, TX 76107

CCFT
Center for Commercialization of Fluorescence Technologies

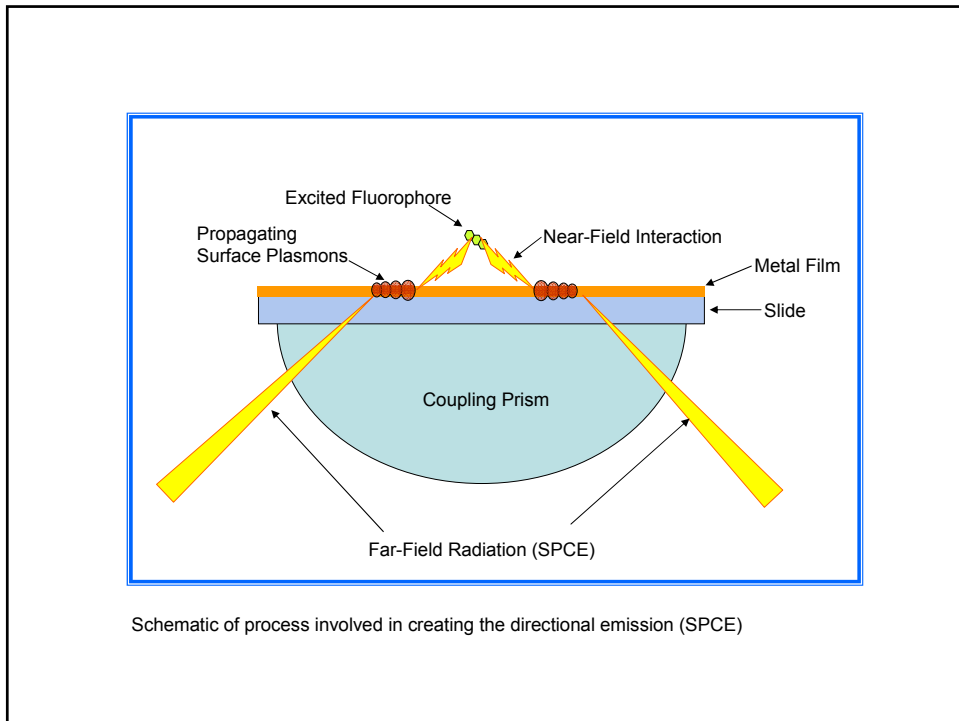
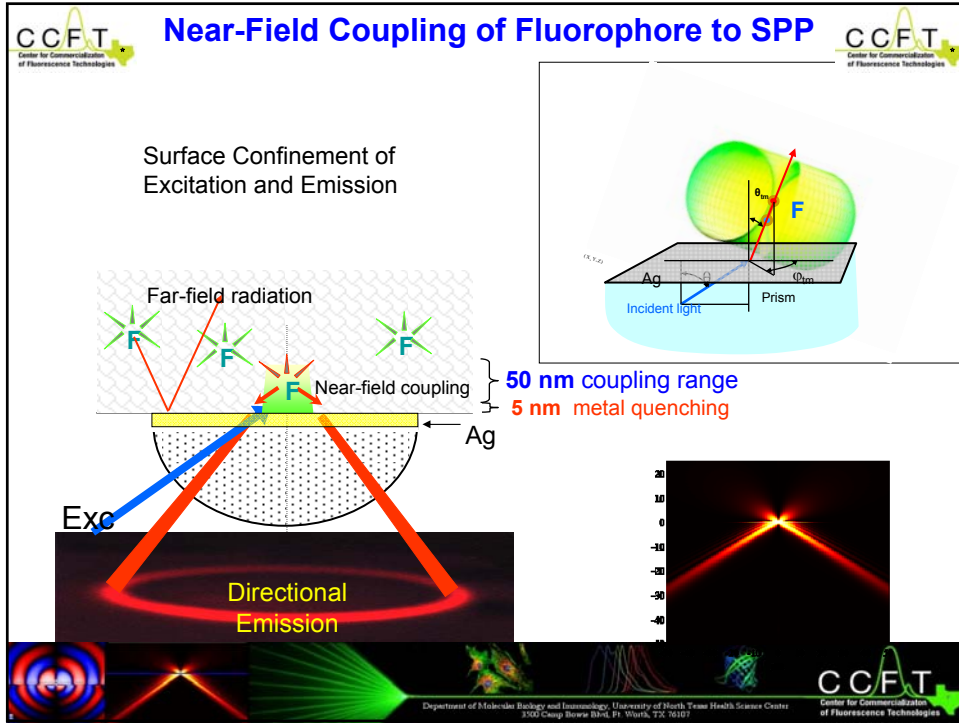

Examples of SPCE - Different Metals

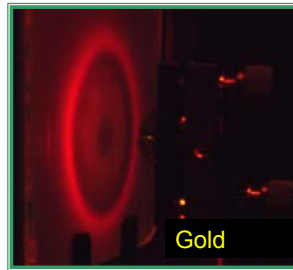
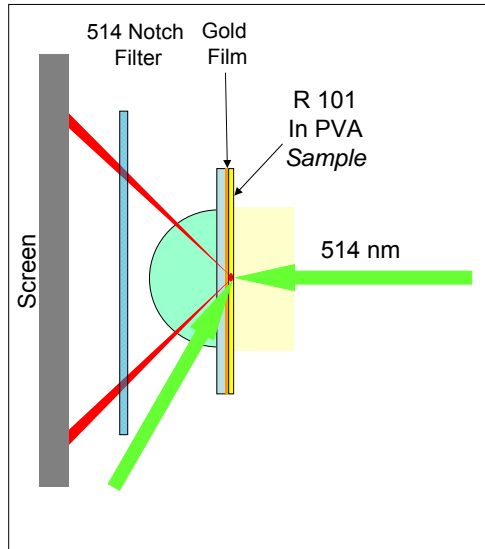

Surface-plasmon-coupled emission: New technology for studying molecular processes. Gryczynski Z., Gryczynski I., Matveeva E., Malicka J., Nowaczyk K., Lakowicz J.R., in Cytometry: New Developments (Methods in Cell Biology, Vol. 75) 4th edition, Darzynkiewicz Z., Roederer M. and Tanke H.J. (Eds), Academic Press, 2004, pp. 73-104

SPCE Angular Dependence

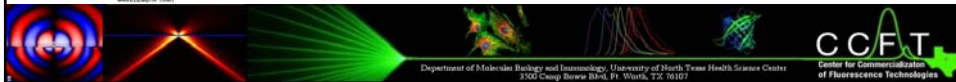
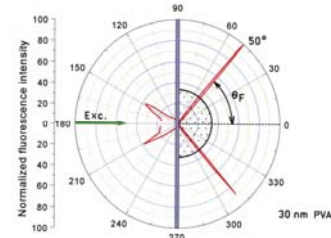
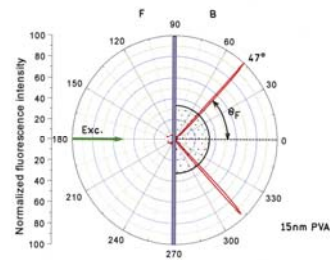
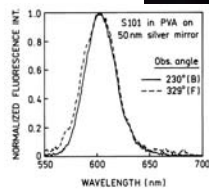
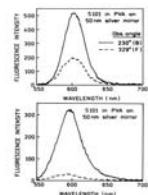
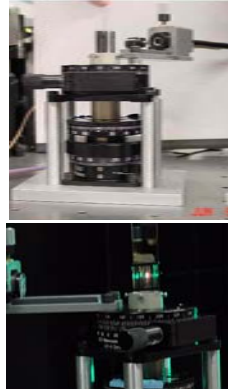
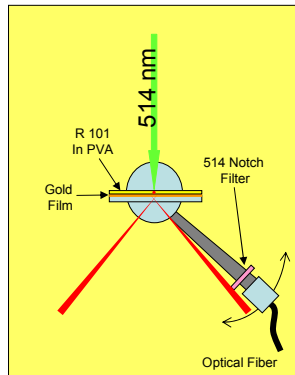

Mixture of Fluorophores – Wavelength Resolution

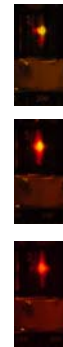
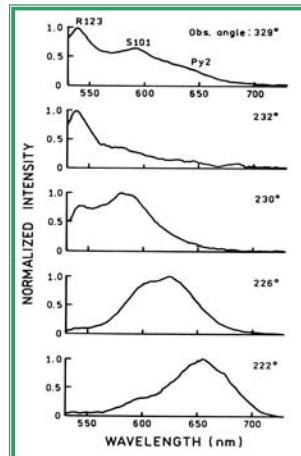
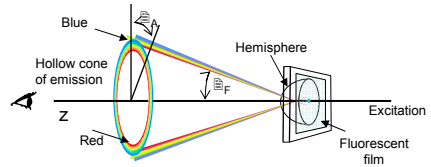
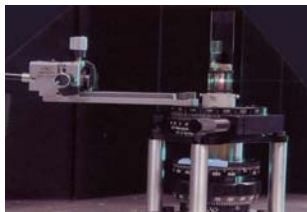
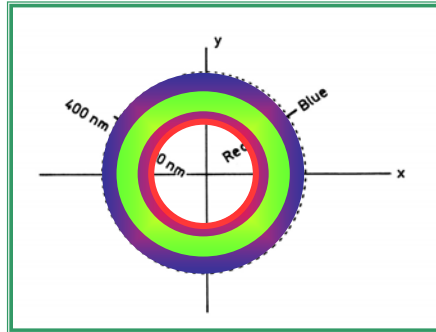

Radiation Diagrams

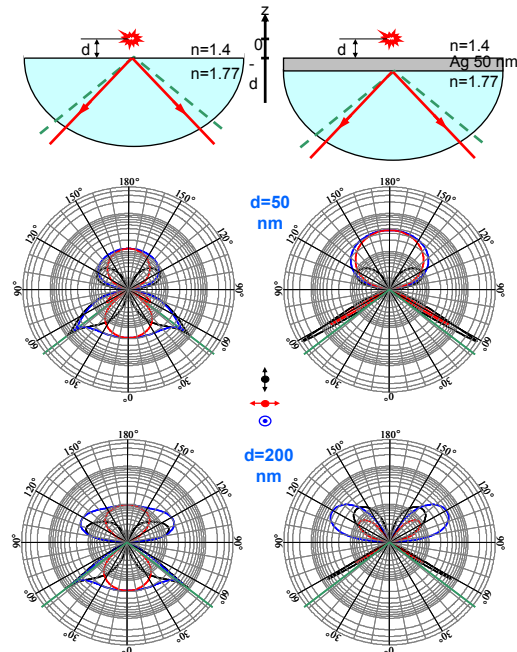

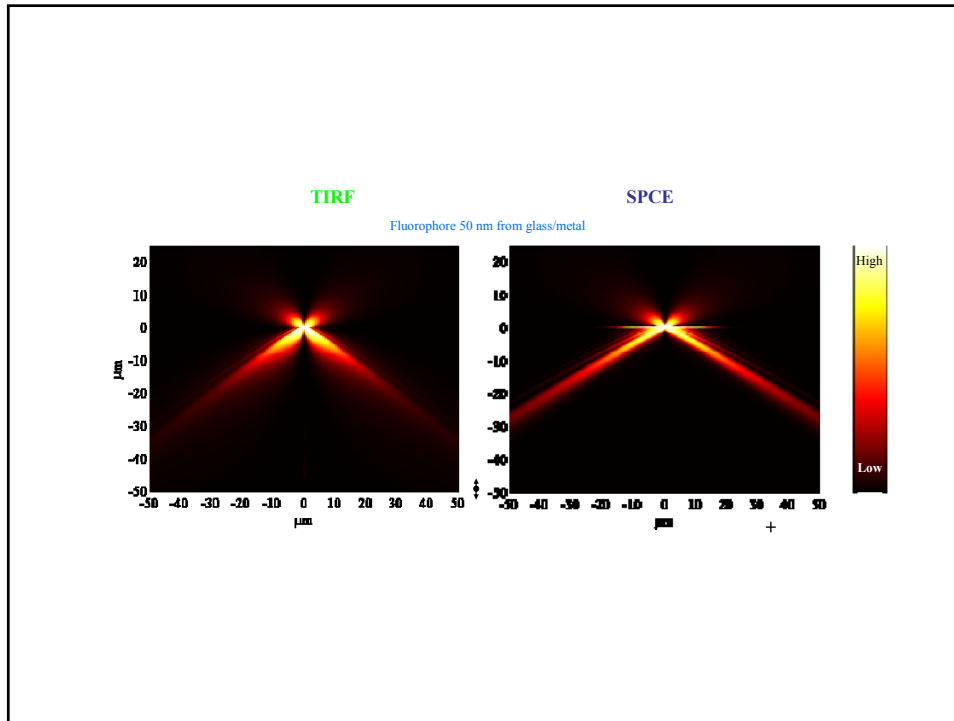

Calculated Reflectance and Electric Fields TIR and SPR Conditions
What is the Effective Distance from the Interface

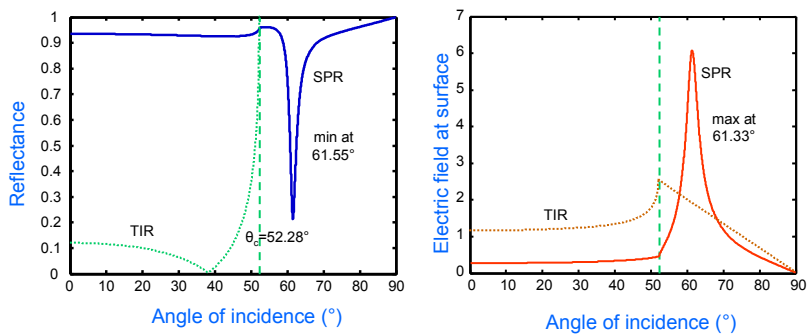

Effective Depth Penetration for SPCE

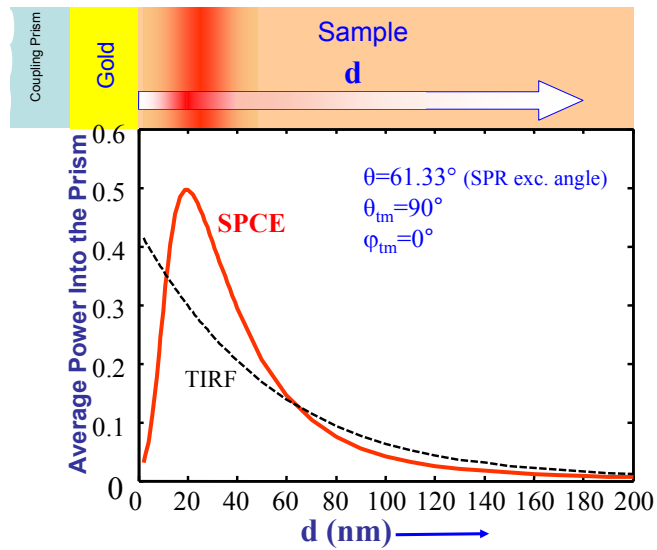

Surface Plasmon Assisted Microscopy (SPAM)

Effective Volume

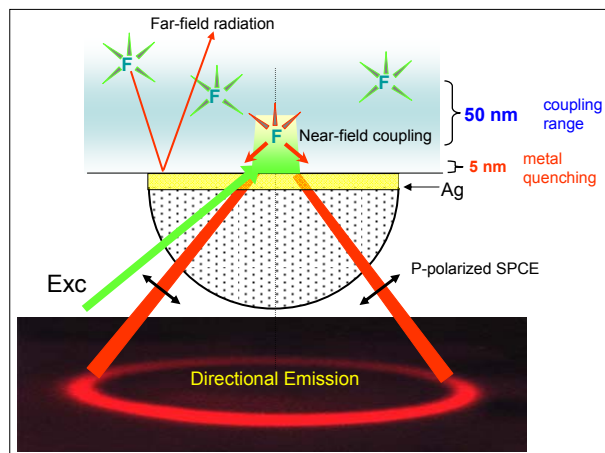

Concept of surface plasmon-coupled emission (SPCE). F is a fluorophore. The excitation energy of fluorophore couples to the surface plasmons and radiates to the glass prism in form of the ring. Far-field radiation is reflected by the metal surface.

Does the SPCE effect depends on fluorescence origin

Schematic for Measurements of ELC Directionality

Chemical Mechanism

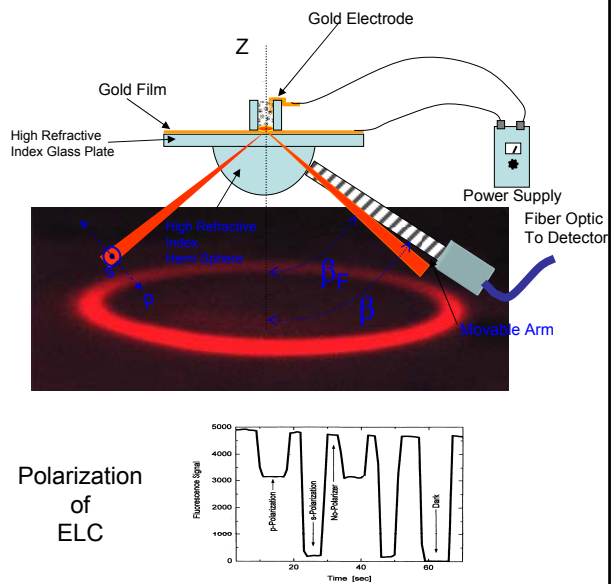
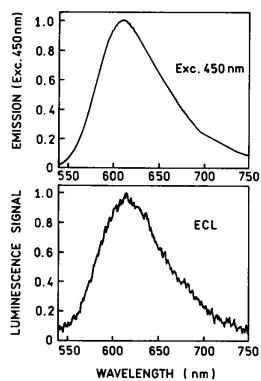
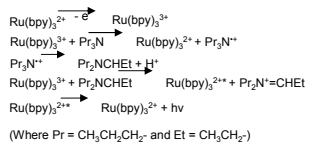

Polarization of ELC

Biomedical Applications of Traveling Plasmons

Fluorescence Immunoassays on Surface

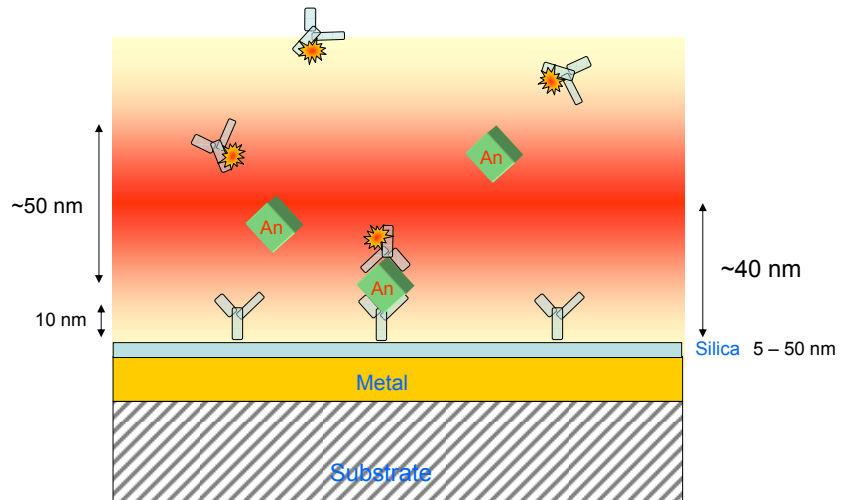

SPCE-based Assays

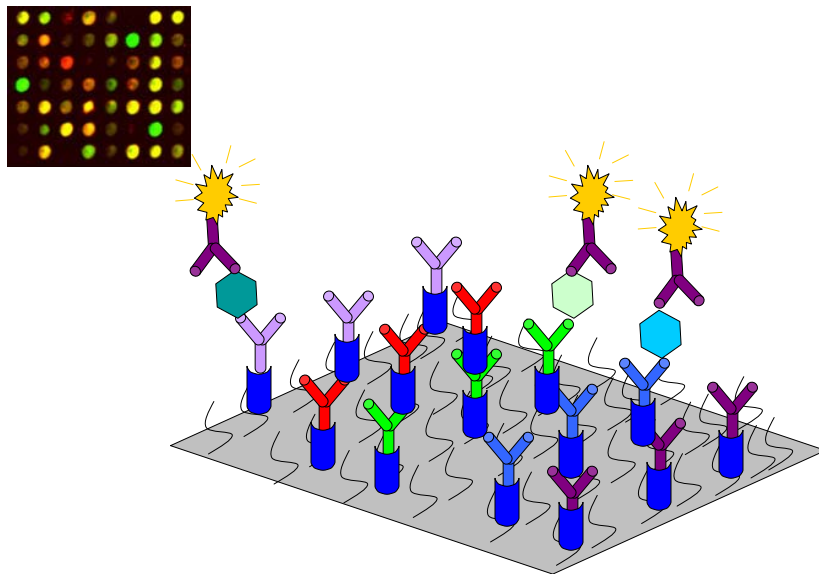

Model Immunoassay with SPCE

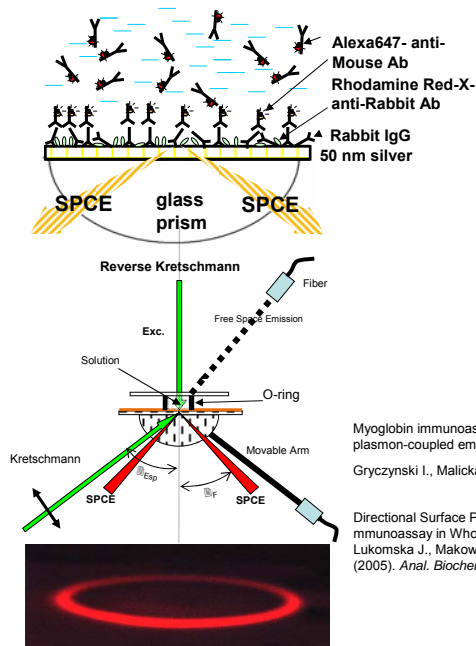

Alexa647- anti-Mouse Ab
Rhodamine Red-X-anti-Rabbit Ab
Rabbit IgG
50 nm silver

Myoglobin immunoassay utilizing directional surface plasmon-coupled emission (2004). Matveeva E., Gryczynski Z., Gryczynski I., Malicka J., Lakowicz J.R., *Anal. Chem.*, **76**, 6287-6292.

Directional Surface Plasmon-Coupled Emission – Application for an Immunoassay in Whole Blood. Matveeva E.G., Gryczynski Z., Malicka J., Lukomska J., Makowicz S., Berndt K.W., Lakowicz J. R., Gryczynski I. (2005). *Anal. Biochem.*, **344**(2), 161-167.

How to Minimize Excitation Volume

The observational volume of **conventional wide-field microscopes** is way too large. For example, in 1 cm long muscle cell there are ~100 billion myosins in the typical observational volume. Even if we observe with diffraction limited optics (high NA objective, laser illumination) the number of observed molecules is ~million.

- The introduction of small observational volumes defined by confocal detection made it possible to limit the thickness to few micrometers (2-3 mm) and eliminate much background (**confocal microscope**).
- **Two-photon (2P) microscope** can reduce the thickness by factor of 2 but this is still too large to define a single molecule.
- **Cinifocal TIRF** can further effectively reduce the thickness by factor of about 50.
- **SPCE** effectively reduce the volume by factor of 2 compare to confocal TIRF and in the same time **reduce background**

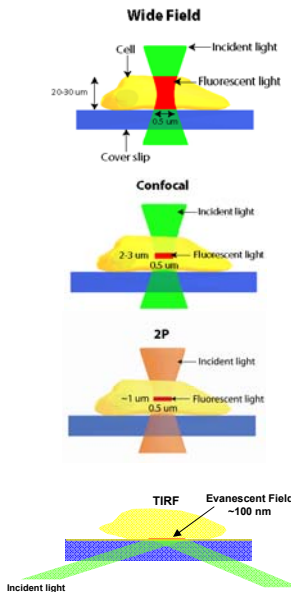

Method	Exp volume (L)	~# of xbs in the volume	Degree of labeling (%)	~# of observed (fluorescent) xbs
Wide field	10^{-14}	10^6	100	10^6
Confocal	3×10^{-16}	2×10^4	2	400
2P	2×10^{-16}	10^4	2	200
TIRF/Con	4×10^{-18}	200	2	4
SPCE	2×10^{-18}	100	2	2

A new method is required !!!

- The method described here, a combination of Surface Plasmon Coupled Emission (SPCE) and confocal microscopy (referred to here as Confocal SPCE) offers hope to see a single molecule in a cell.
- The principle is shown schematically at right. The light which impinges on a silver-plated cover-slip made from sapphire at SPR angle, penetrates the silver and resonates with surface plasmons to create extremely bright fluorescence (~50 x brighter than fluorescence excited by TIR).

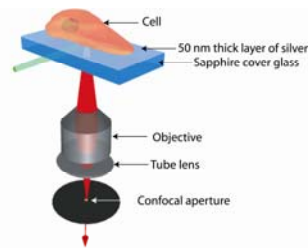
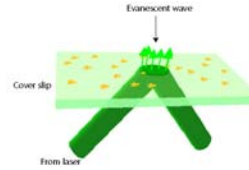

Principle of the method

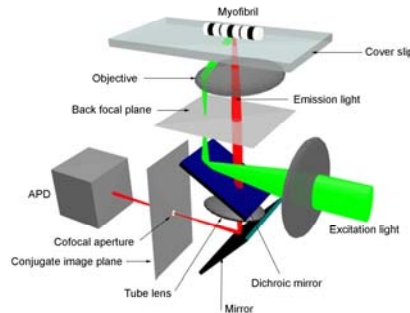

Method	Experimental volume (L)	~Number of xbs in the volume	Degree of labeling (%)	~Number of observed (fluorescent) xbs
SPCE	10^{-18}	100	2	2

Principles of SPCE Microscopy

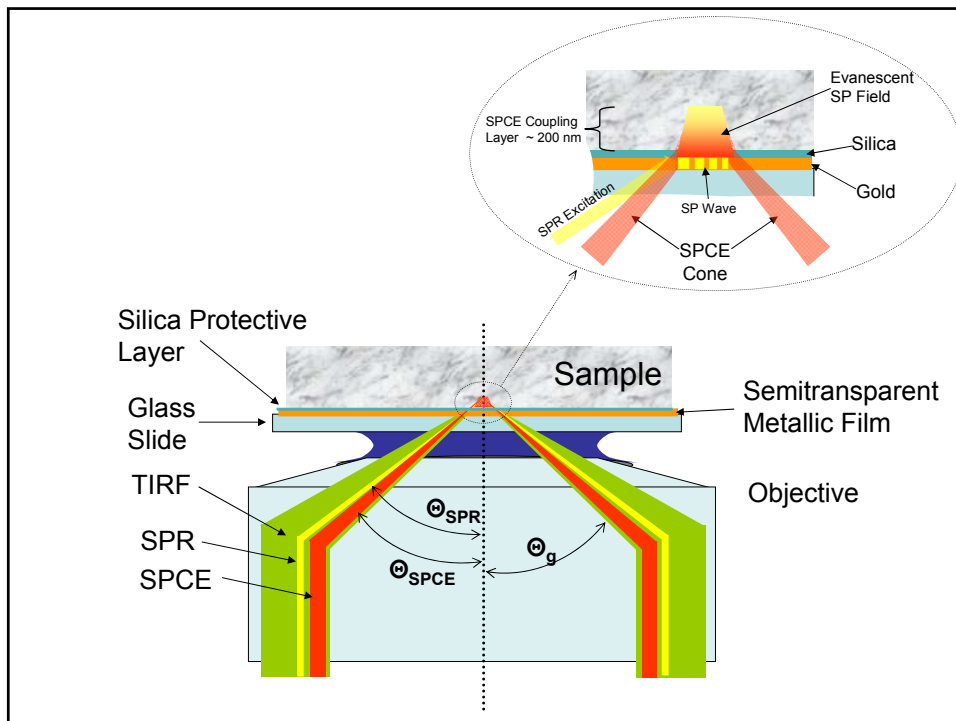

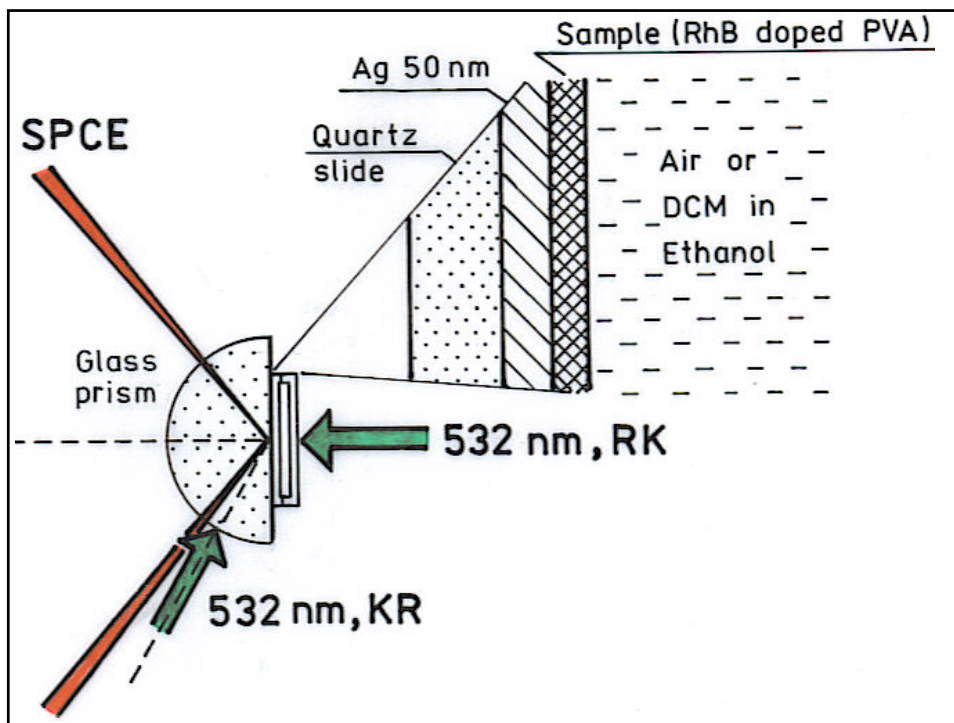
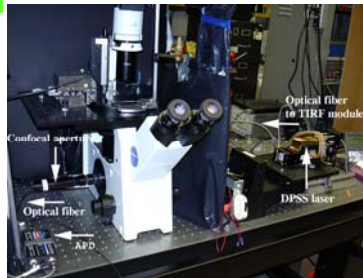
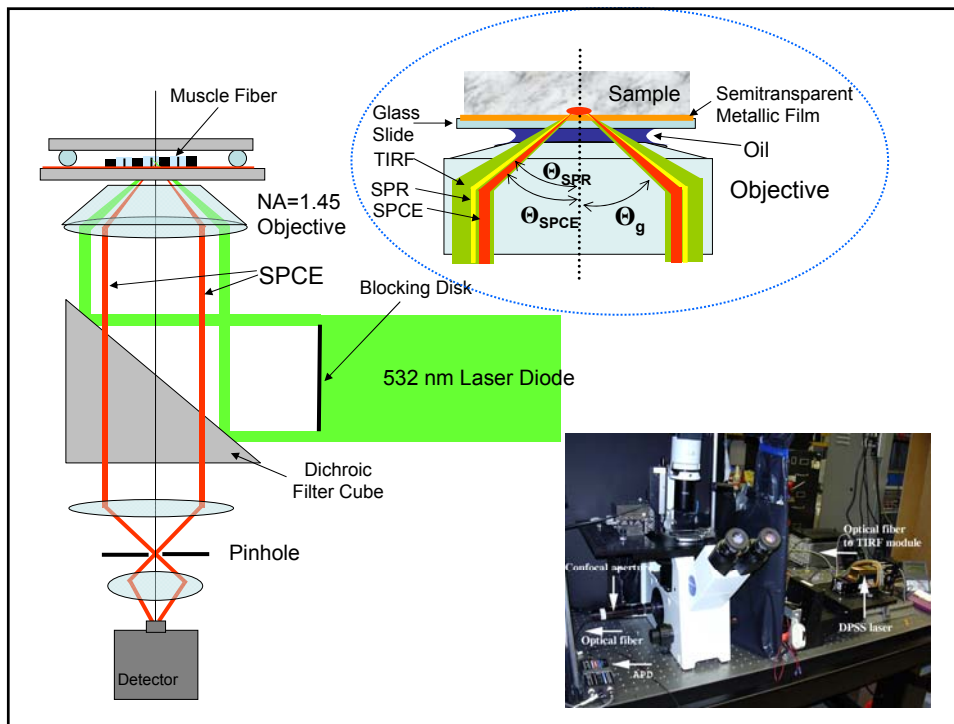

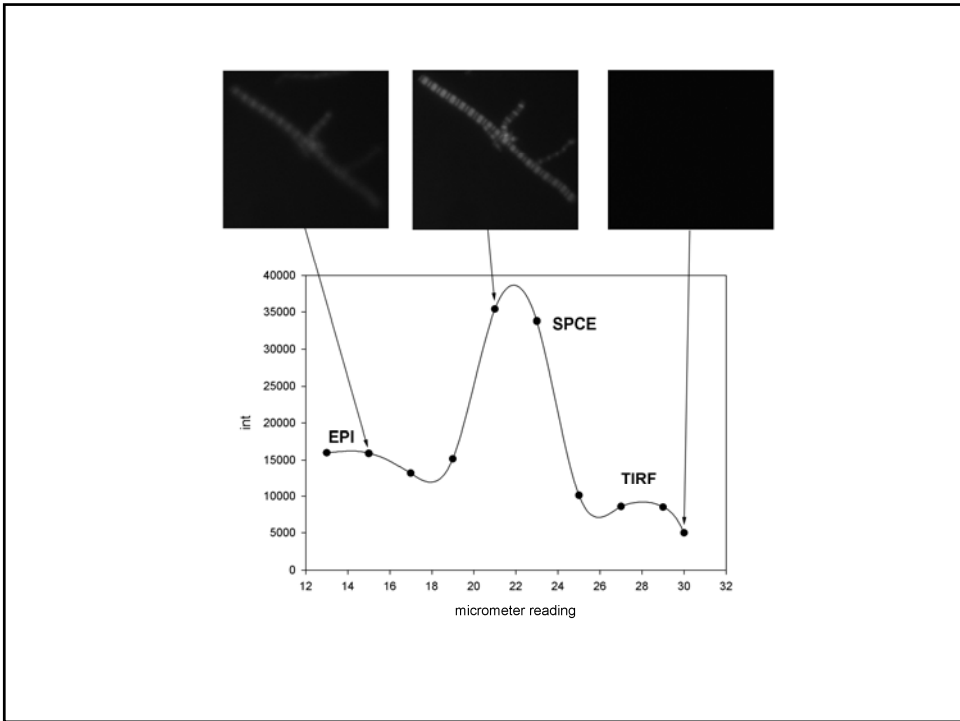
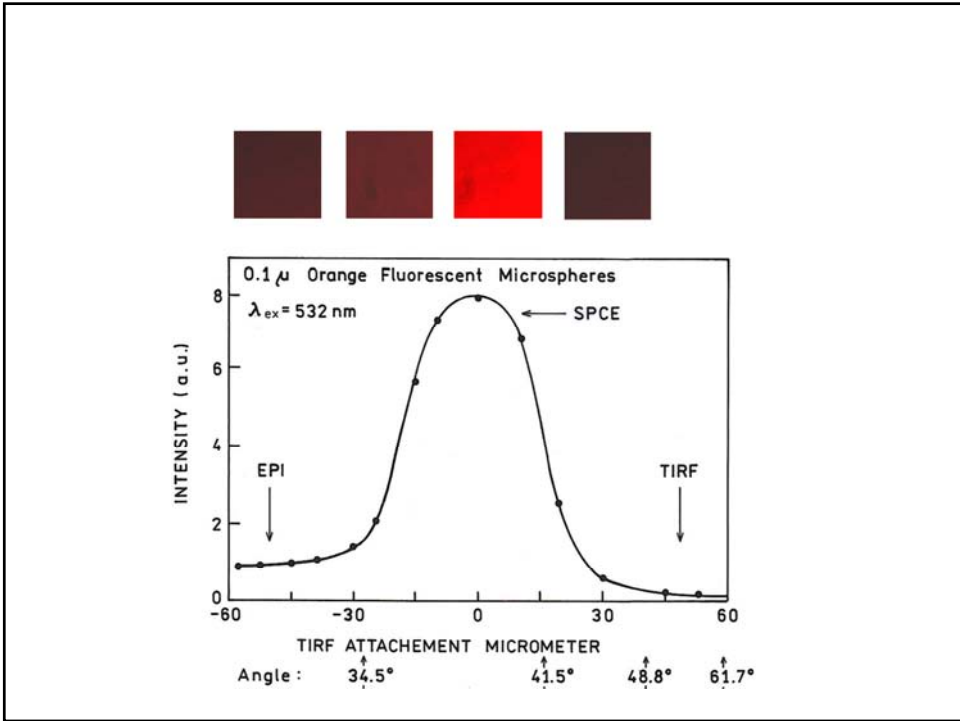

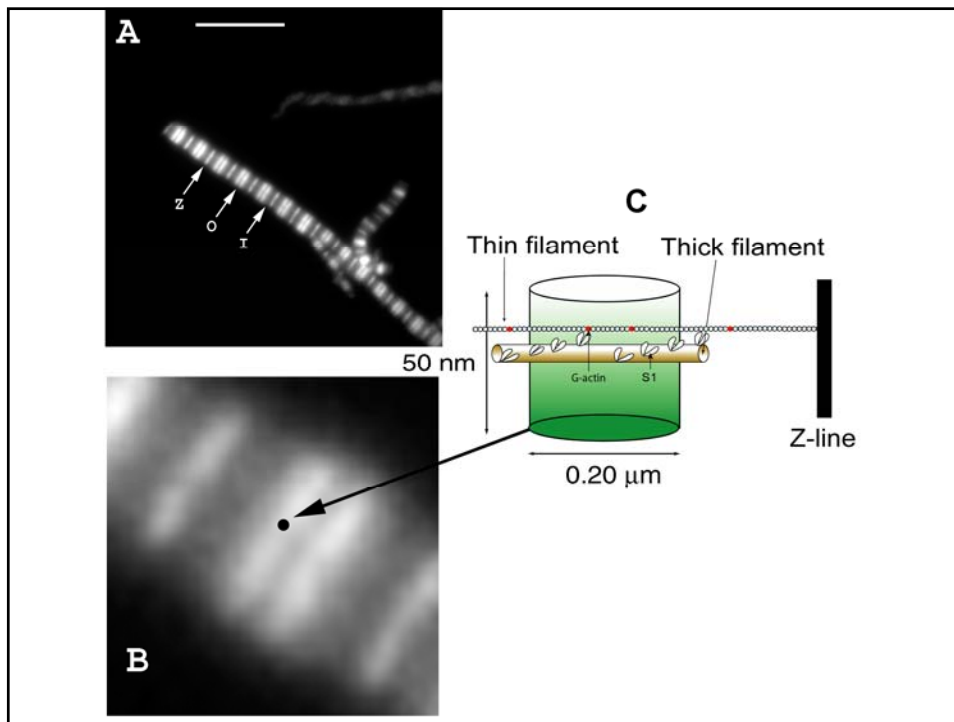

Muscle, cntd

Confocal SPCE signal from rigor myofibril. The data was collected from the overlap zone. Myofibril labeled with 0.1 μM rhodamine-phalloidin on gold coverslips. The exciting light was perpendicular to the plane of coverslip (p-polarization).

A: Fluorescence intensity.

B: intensity on expanded scale, gray-original signal, red-low pass filtered.

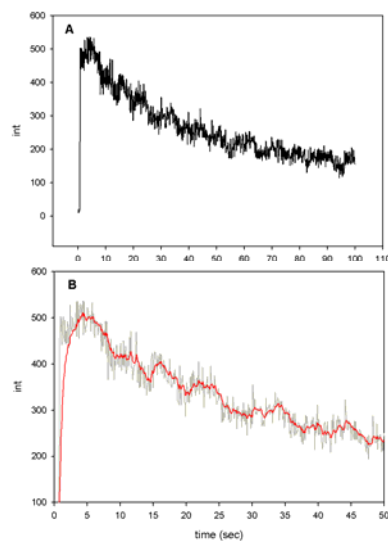

Photostability

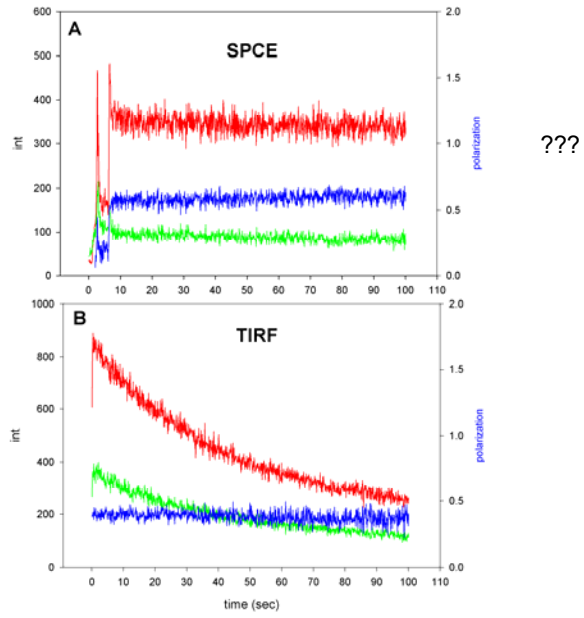

FCS with Surface Plasmons

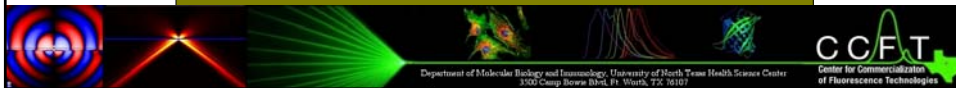
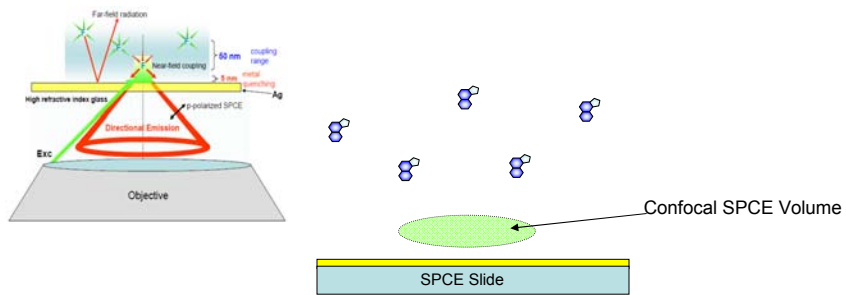

$$G(t) = 1 + \frac{1}{2N} \frac{\sum_n \frac{d_n}{d_n + d_m} A_n A_m R_{nm}(t)}{\sum_n \frac{d_n}{d_n + d_m} A_n A_m}$$

$$R_{nm}(t) = \left(1 + \frac{Dt}{\sigma^2}\right)^{-1} \left(\left(1 - \frac{2Dt}{d_n^2}\right) \operatorname{erfc}\left(\sqrt{\frac{Dt}{d_n^2}}\right) \exp\left(\frac{Dt}{d_n^2} + \sqrt{\frac{4Dt}{d_n^2}}\right) \right)$$

$$R_{nm}(t) = \left(1 + \frac{Dt}{\sigma^2}\right)^{-1} \left(\frac{d_m}{d_n - d_m} \operatorname{erfc}\left(\sqrt{\frac{Dt}{d_n^2}}\right) \exp\left(\frac{Dt}{d_n^2}\right) + \frac{d_n}{d_n - d_m} \operatorname{erfc}\left(\sqrt{\frac{Dt}{d_m^2}}\right) \exp\left(\frac{Dt}{d_m^2}\right) \right)$$

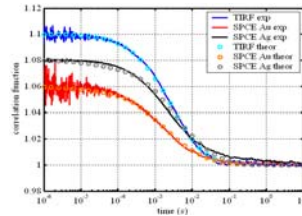
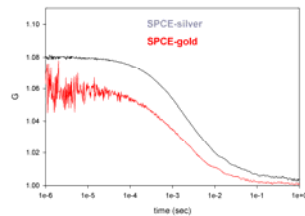

Fluorescence Correlation Spectroscopy in Surface Plasmon Coupled Emission Microscopy. (2006) Borejdo, J., N. Calander, Z. Gryczynski, and I. Gryczynski. *Optic Express*. 14. (17), 7878-7888.

Where Surface Confined Fluorescence Could Be Used Visualizing Membrane Processes

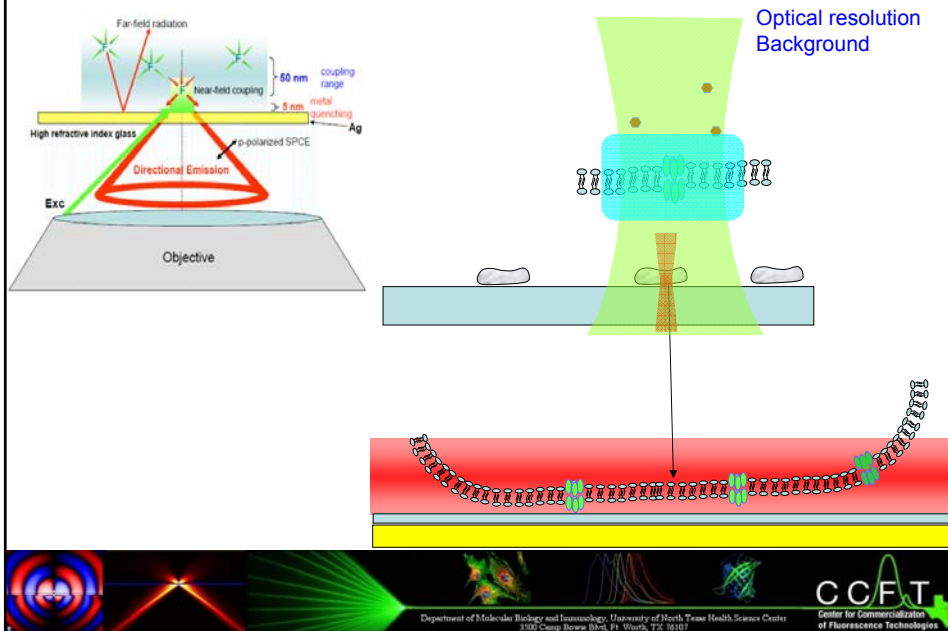

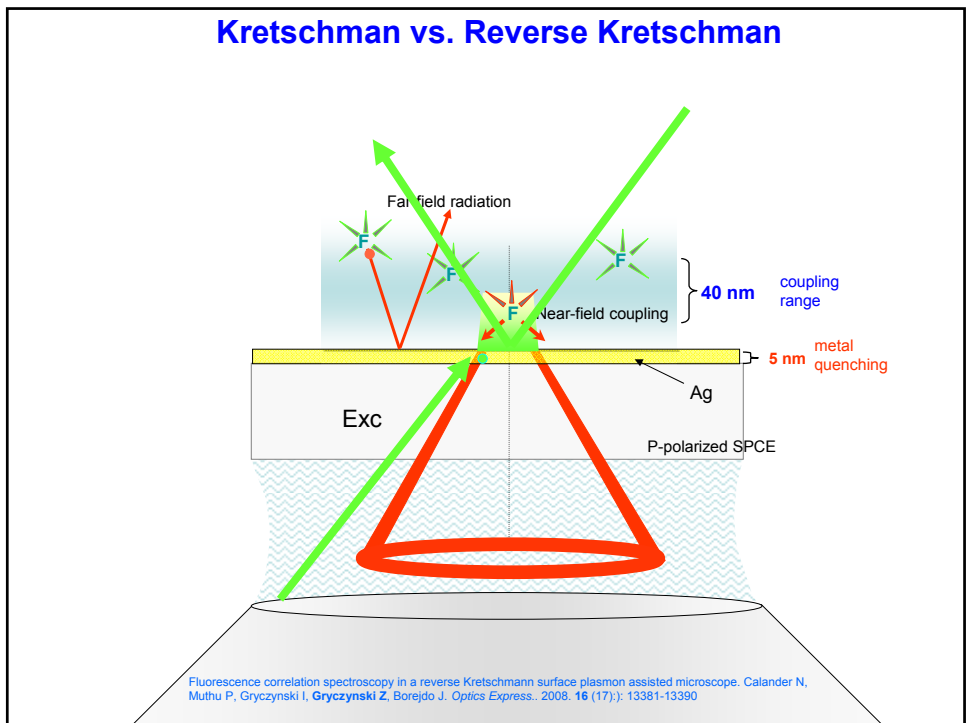
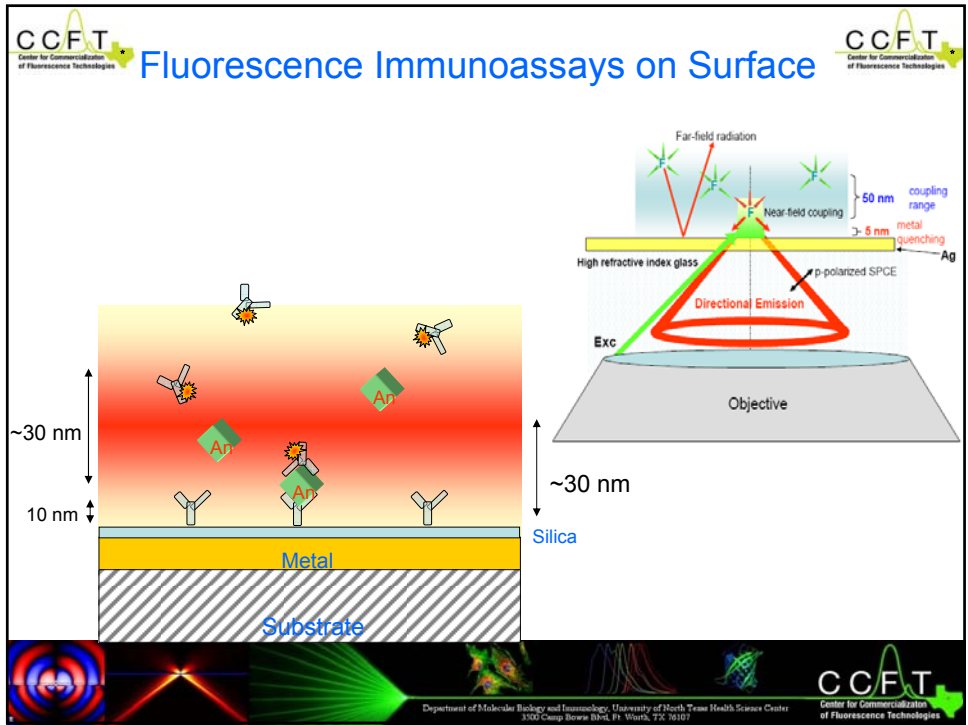

Model Hybridization Assay with SPCE

Ratiometric Detection of Wavelength Resolved SPCE

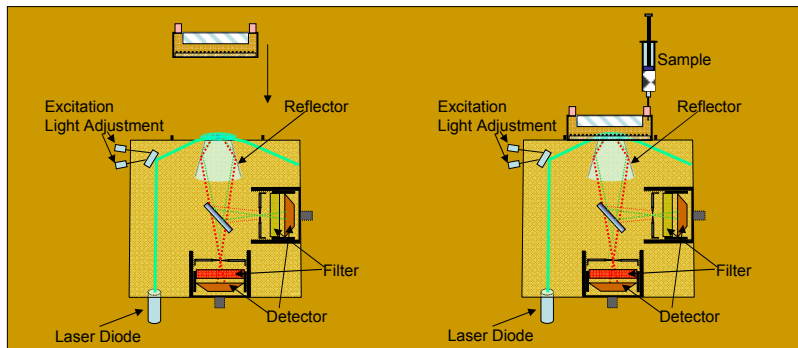
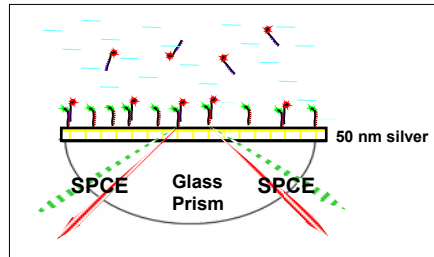

Another Interesting Property of SPCE

Waveguide Assisted SPCE

SPR – Salomon and Tolin

SPCE from Thick and Thin PVA Films

Effects of Film Thickness on the Angular Distribution of SPCE

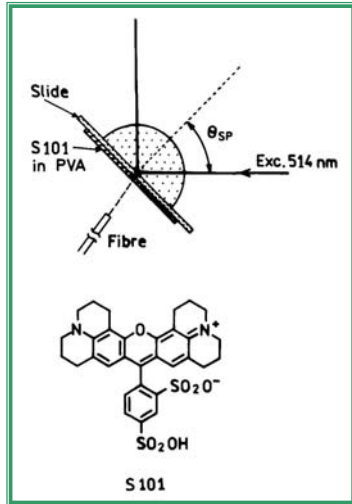

150 nm thick PVA 290 nm thick PVA

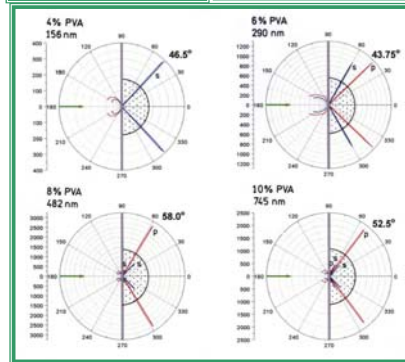
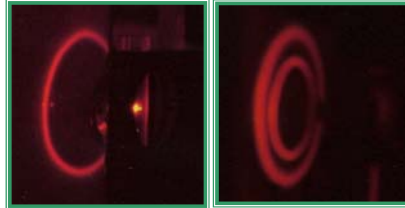

p & s Ring Polarization

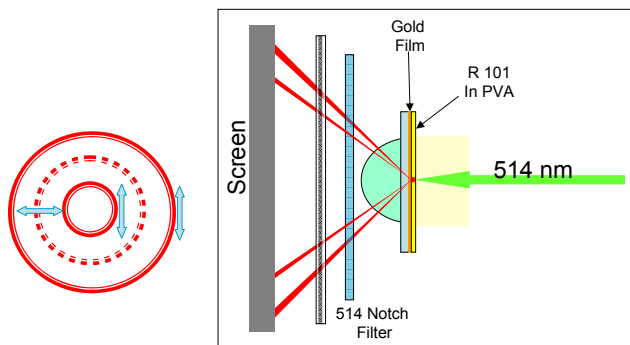

Vertical

None

Horizontal

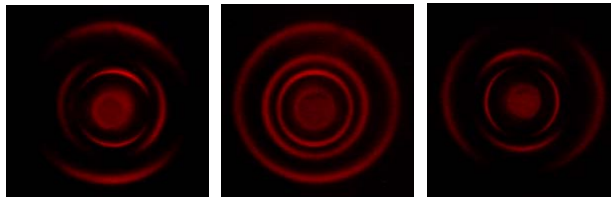

Effect of Orientation of Emitting Dipole

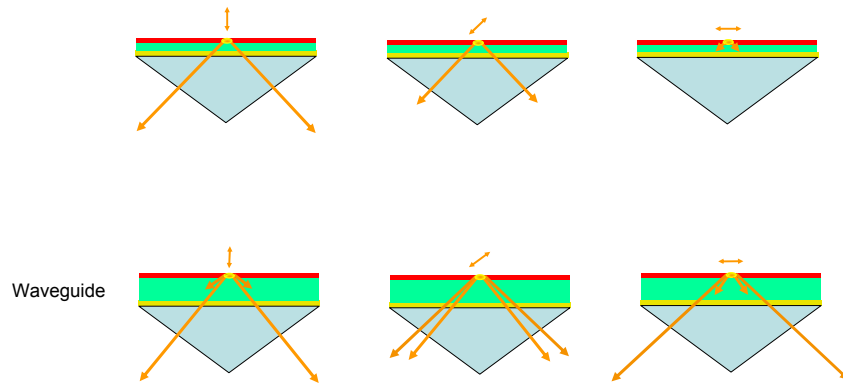

New Concept for Measuring Conformational Changes

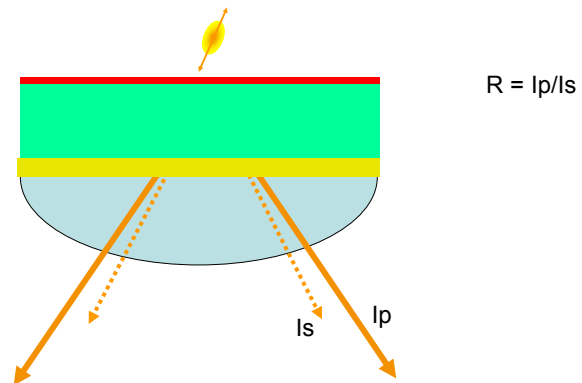

Studying Conformational Dynamics

Process that Involve Conformational Change

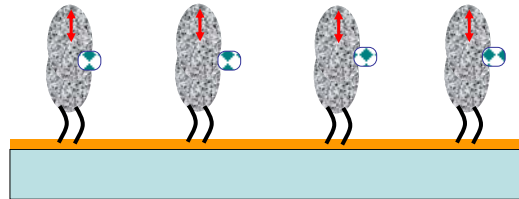

Utilizing the Waveguide Technology

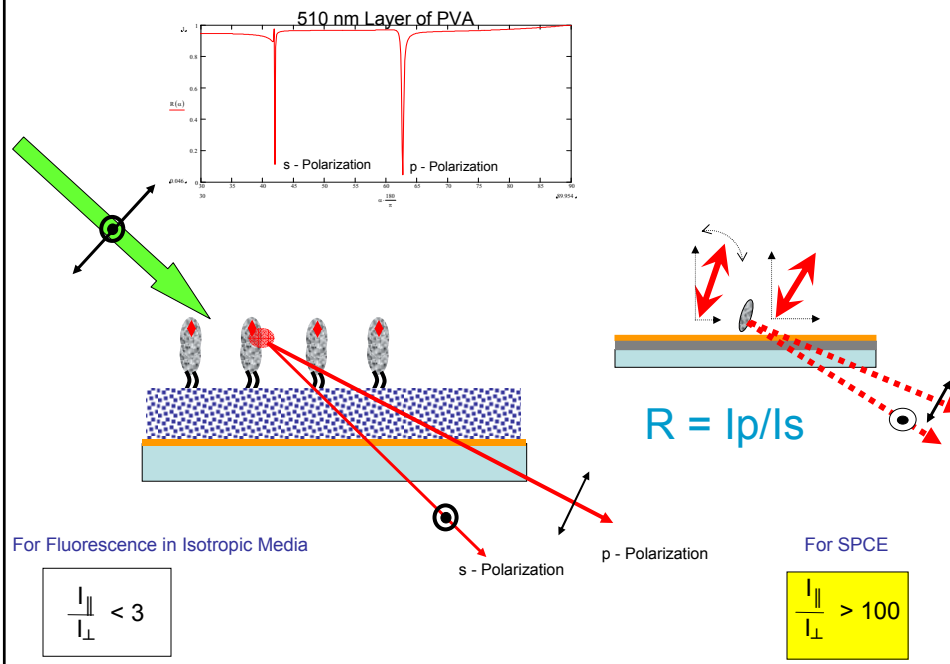

Theoretical Calculation

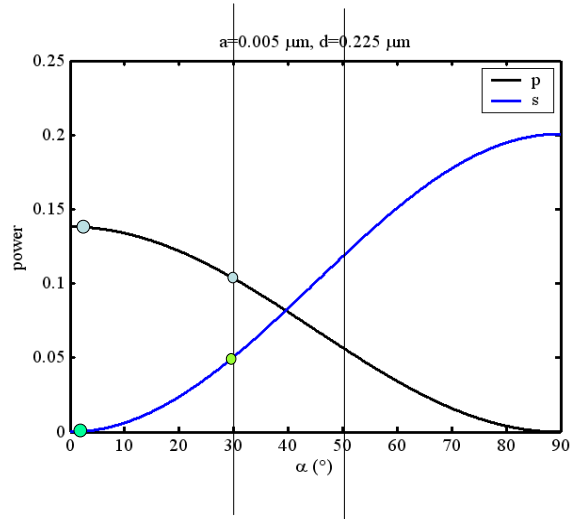
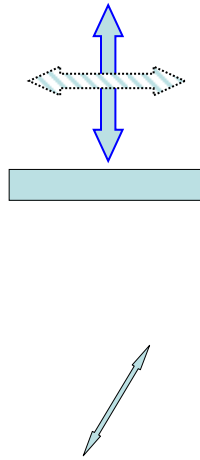

Power flow of p-polarized (black) and s-polarized light versus dipole angle α .

**SPCE Microscope - Tool
For Direct Detection of
Conformational Changes**

Conformational Change Upon Ligand Binding

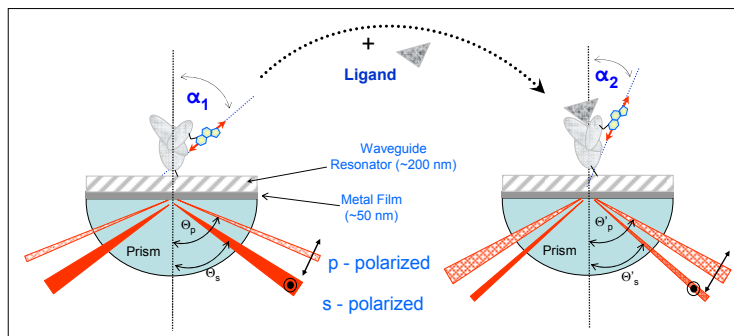

A schematic description of conformational change occurring upon ligand binding. We will detect bounding (mass change), conformational change (reorientation of the binding side), and by time-resolved measurement change in the protein mobility (if induced by binding).

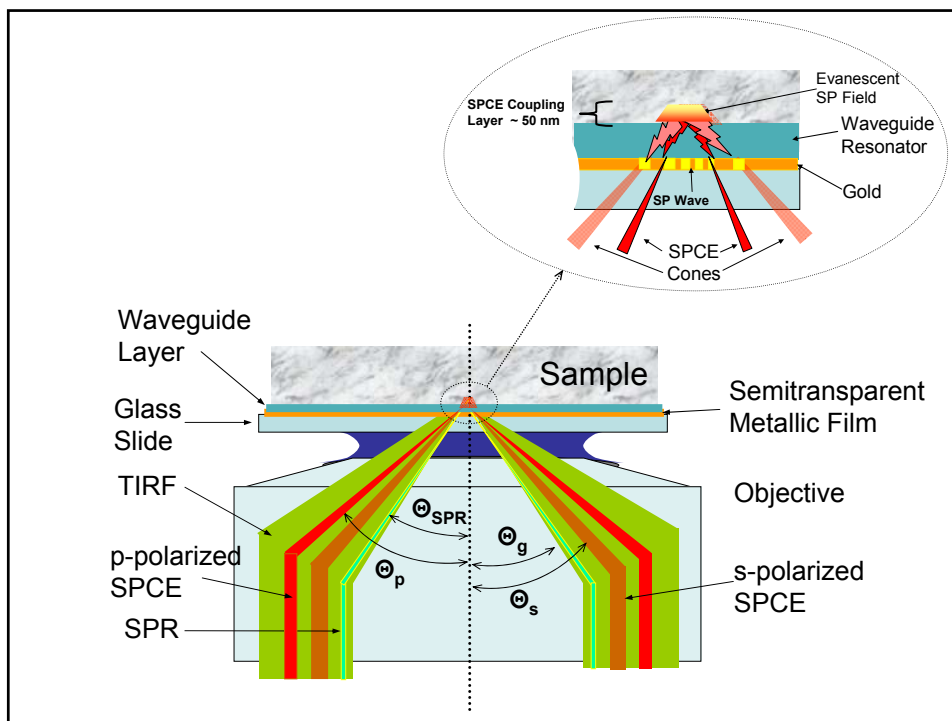

Detecting Different Motions – in plane and out-of plane

Collaboration with: Joerg Enderline, Gottingen; John Schetz, Pharmacology, UNTHSC; Jim Harper, UNH.

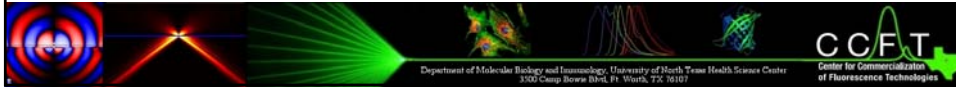
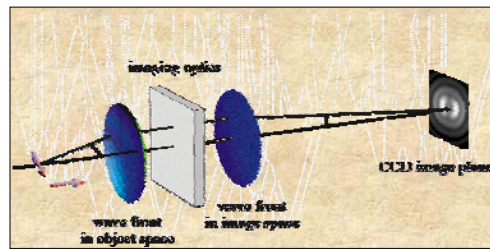
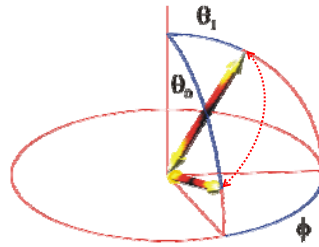
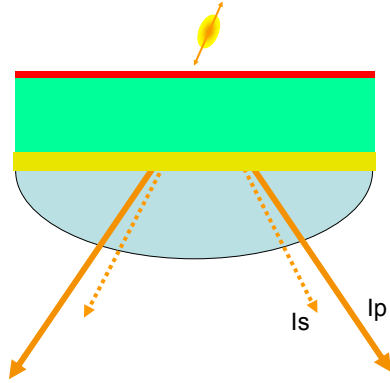

SPCE From Single Horizontal Dipole What about in plane rotations?

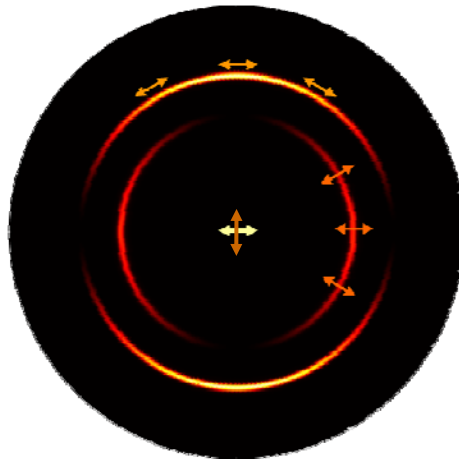

Molecular Motion in Azimuthal Angle

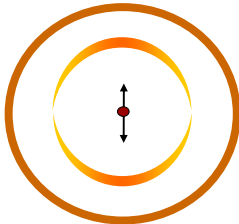

Schematic Concept for Waveguide Assisted SPCE Microscope

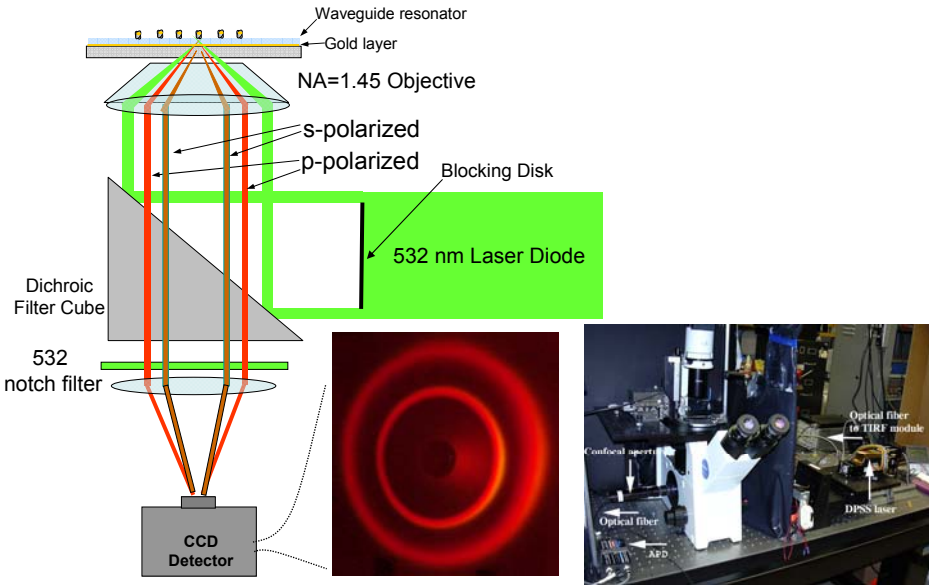

Rotational diffusion of molecules

New after submission

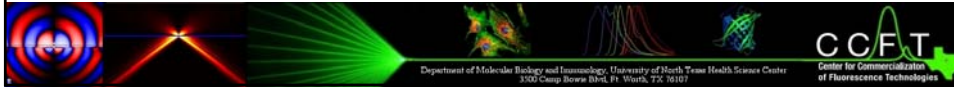
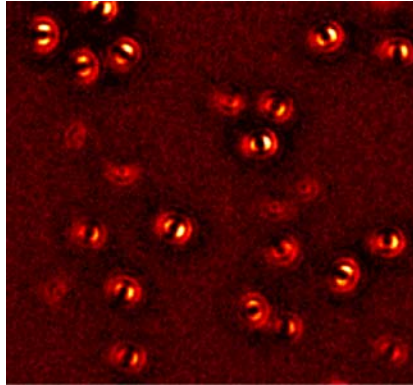

A Model System

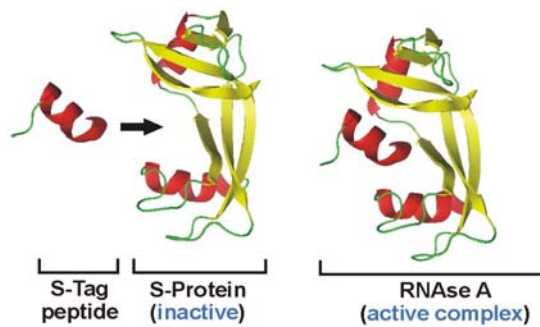

Interactions between protein pairs in bovine pancreatic ribonuclease A (RNase A). The structure of the crystalline protein is rendered as cartoon depicting the secondary structural elements with helices colored red, sheets colored yellow and random coils colored green. A) Cleavage of the N-terminal 15 amino acids of RNase A produces what is called an S-Tag peptide and an enzymatically inactive protein called S-protein. B) The high affinity binding of the S-Tag peptide to the inactive S-Protein forms a bimolecular complex with RNase activity.

Acknowledgment

Emerging Technology Fund of Texas
National Institute of Health (NIBIB & NCI)
National Science Foundation
BITC
Philip Morris External Research Program

CCFT Team

Ignacy Gryczynski
Julian Borejdo
Nils Calander
Evgenia Matveeva
Irina Akopowa
Gabor Laczko
Tanya Shtoyko
Ralal Luchowski
Mariusz Szabelski
John Talent

Students

Priya Mathu
Sashank Bharil
Pabak Sakar
Prasad Yala Maticola