

# Basic Instrumentation

*Joachim Mueller*

*Principles of Fluorescence Spectroscopy*  
 Genova, Italy  
 June 30 – July 3, 2008

Figure and slide acknowledgements:  
 Theodore Hazlett

---

---

---

---

---

---

---

---

## Fluorometer



ISS PC1 (ISS Inc., Champaign, IL, USA)



Fluorolog-3 (Jobin Yvon Inc, Edison, NJ, USA)





QuantaMaster (OBB Sales, London, Ontario N6E 2S8)



---

---

---

---

---

---

---

---

## Fluorometer Components

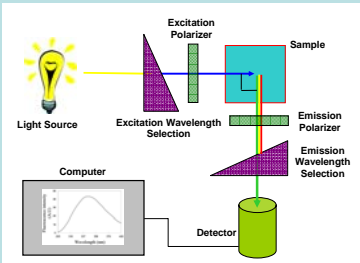

Note: Both polarizers can be removed from the optical beam path

---

---

---

---

---

---

---

---

## Fluorometer Components

Light Source

Detectors

Wavelength Selection

Polarizers

---

---

---

---

---

---

---

---

### The Laboratory Fluorometer

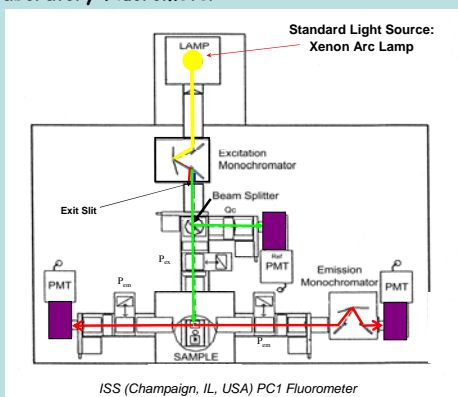

---

---

---

---

---

---

---

---

## Light Sources



---

---

---

---

---

---

---

---







## Photon Multiplier Tube

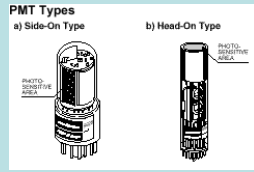

Microchannel Plate Detector (MCP)



MCP & Electronics  
(ISS Inc. Champaign, IL USA)

For fast modulation  $f > 500$  MHz

---

---

---

---

---

---

---

---

---

---

---

---

## The Classic PMT Design

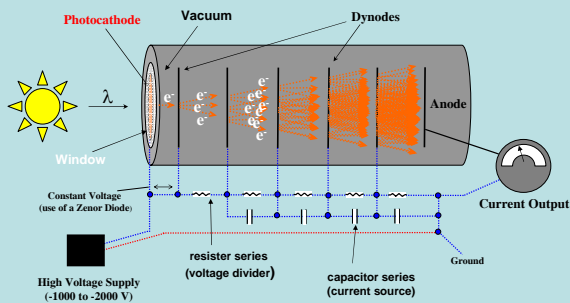

---

---

---

---

---

---

---

---

---

---

---

---

## Hamamatsu R928 PMT Family

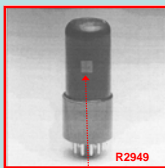

Window with  
Photocathode Beneath

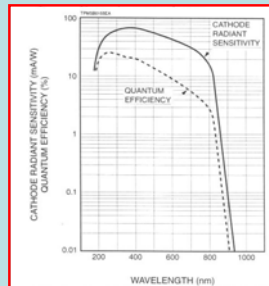

---

---

---

---

---

---

---

---

---

---

---

---

### PMT Quantum Efficiencies

Cathode Material

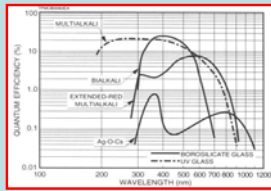

Window Material

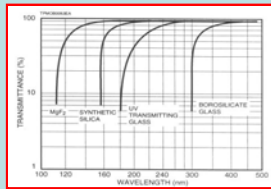

---

---

---

---

---

---

---

---

---

---

---

---

### Photon Counting (Digital) and Analog Detection

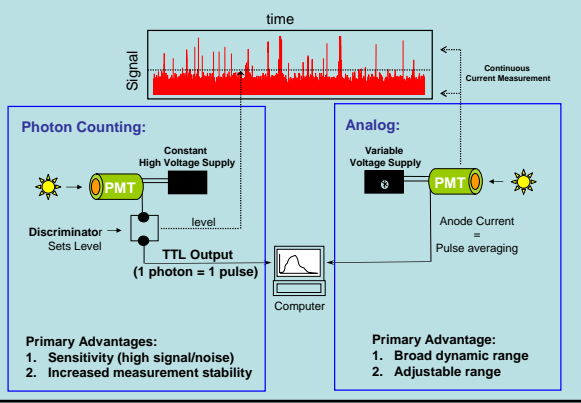

---

---

---

---

---

---

---

---

---

---

---

---

### PMT Geometries

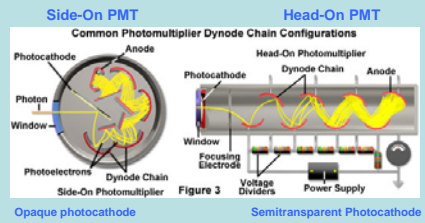

Side-on PMTs have slightly enhanced quantum efficiency over Head-on PMTs  
 Side-on PMTs often have larger afterpulsing probabilities than Head-on PMTs  
 Side-on PMTs count rate linearity less than for Head-on PMTs  
 Head-on PMTs provide better spatial uniformity than Side-on PMTs  
 Side-on PMTs have faster response time than Head-on PMTs (compact design)  
 Side-on PMTs are less affected by a magnetic field than Head-on PMTs

---

---

---

---

---

---

---

---

---

---

---

---

## Avalanche Photodiode (APD)

### APD for analog detection



The silicon avalanche photodiode (Si APD) has a fast time response and high sensitivity in the near infrared region. APDs are available with active areas from 0.2 mm to 5.0 mm in diameter and low dark currents (selectable).  
Photo courtesy of Hamamatsu

### APD for photon counting



Single photon counting module (SPCM) from Perkin-Elmer

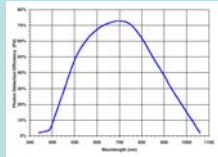

---

---

---

---

---

---

---

---

---

---

---

---

## Wavelength Selection

- Fixed Optical Filters
- Tunable Optical Filters
- Monochromators

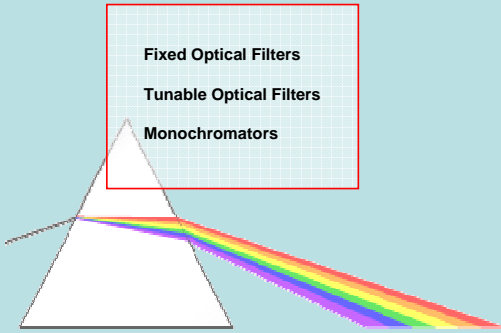

---

---

---

---

---

---

---

---

---

---

---

---

## Optical Filter Channel

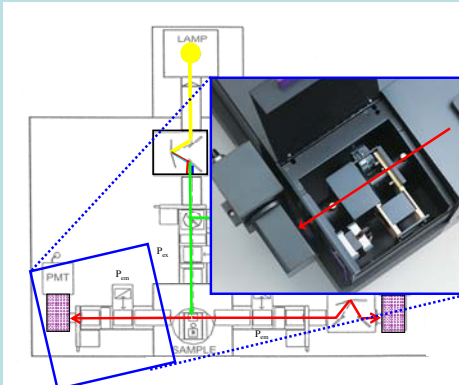

---

---

---

---

---

---

---

---

---

---

---

---

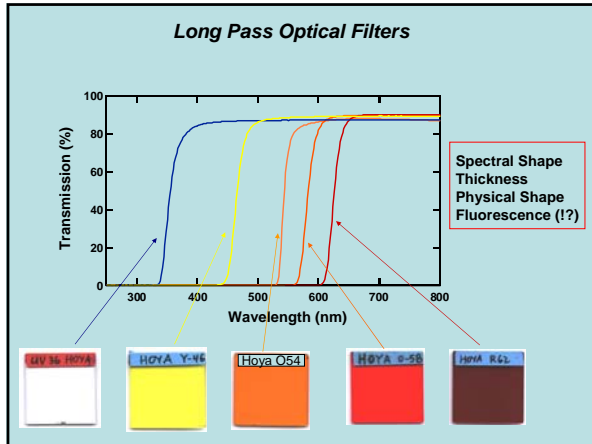

---

---

---

---

---

---

---

---

---

---

---

---

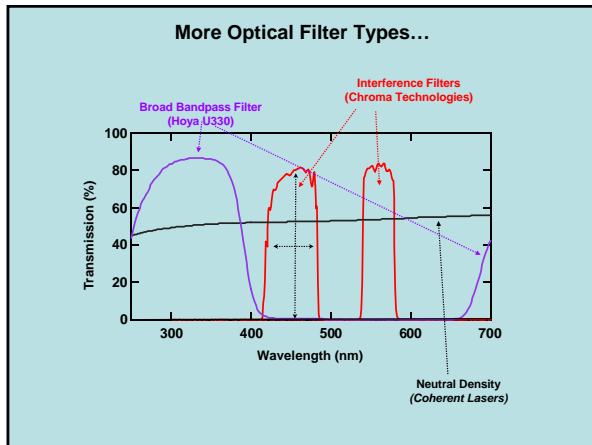

---

---

---

---

---

---

---

---

---

---

---

---

### Tunable Optical Filters

**Liquid Crystal Filters:**  
 An electrically controlled liquid crystal elements to select a specific visible wavelength of light for transmission through the filter at the exclusion of all others.

**AO Tunable Filters:**  
 The AOTF range of acousto-optic devices are solid state optical filters. The wavelength of the diffracted light is selected according to the frequency of the RF drive signal.

---

---

---

---

---

---

---

---

---

---

---

---

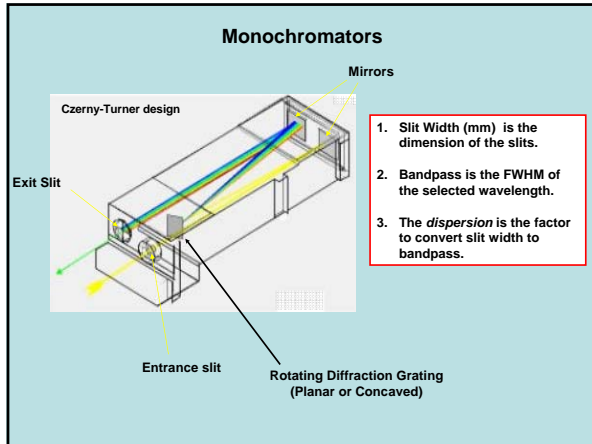

---

---

---

---

---

---

---

---

---

---

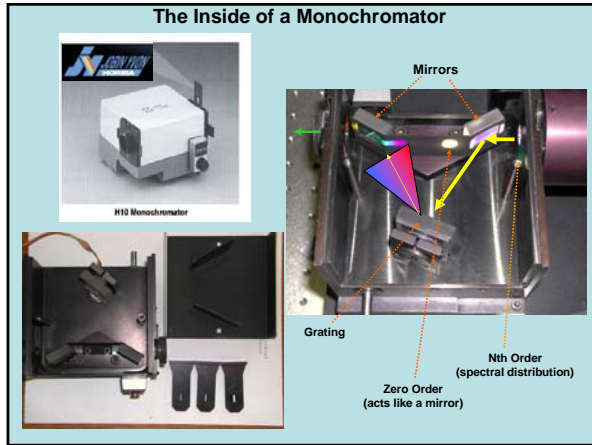

---

---

---

---

---

---

---

---

---

---

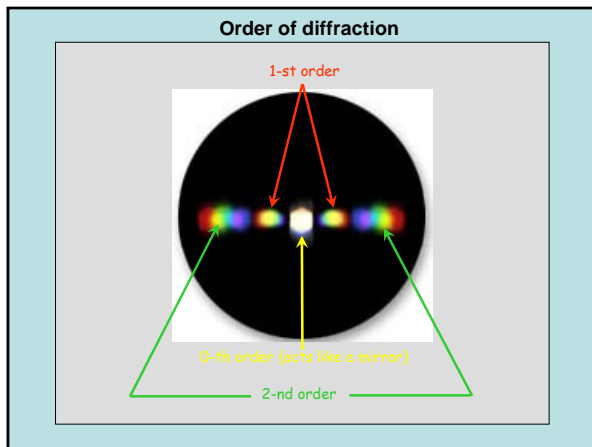

---

---

---

---

---

---

---

---

---

---



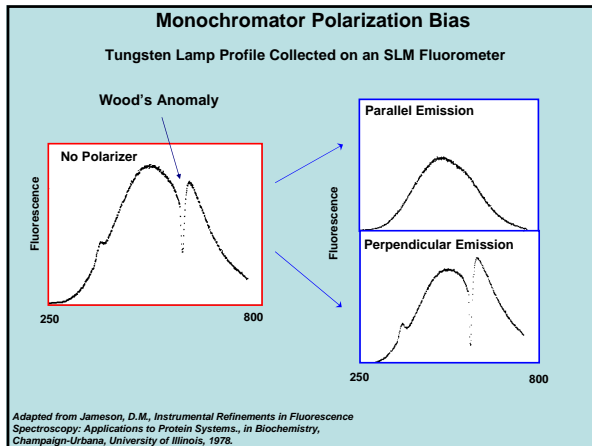

---

---

---

---

---

---

---

---

---

---

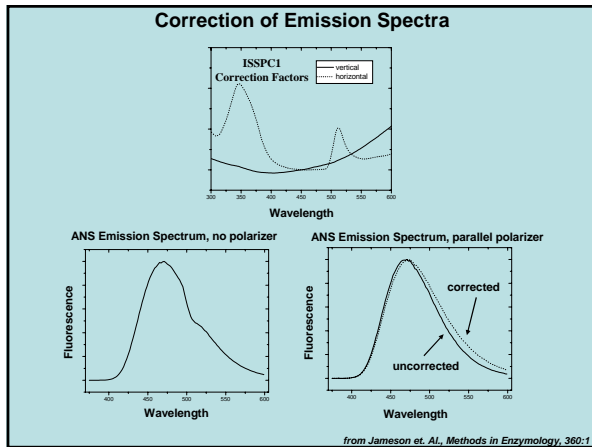

---

---

---

---

---

---

---

---

---

---

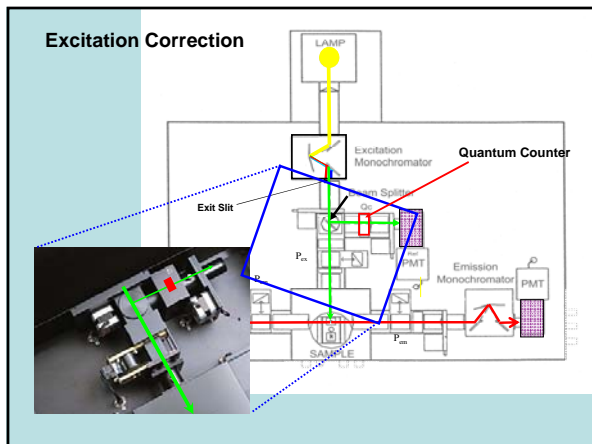

---

---

---

---

---

---

---

---

---

---



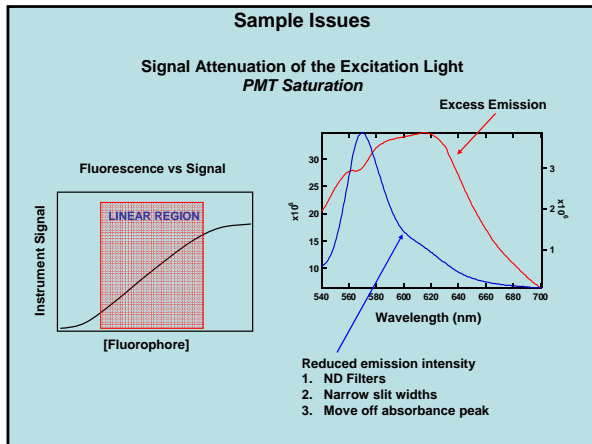

---

---

---

---

---

---

---

---

---

---

---

---

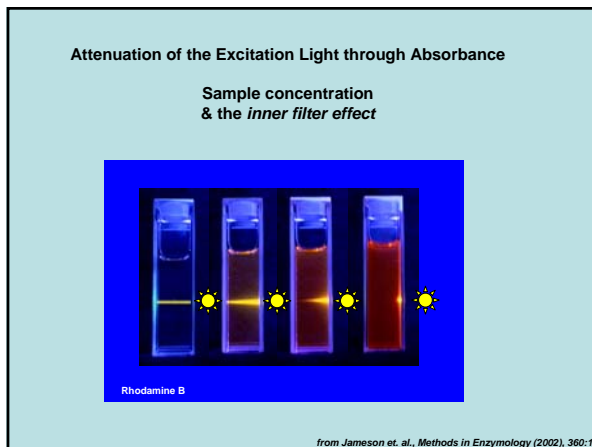

---

---

---

---

---

---

---

---

---

---

---

---

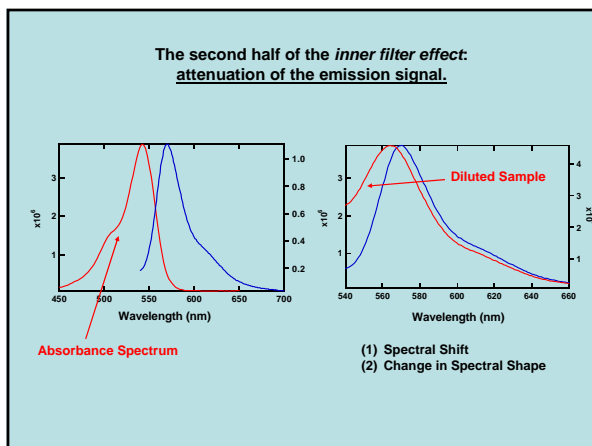

---

---

---

---

---

---

---

---

---

---

---

---

### How do we handle highly absorbing solutions?

**Quartz/Optical Glass/Plastic Cells**

4 Position Turret  
SPEX Fluoromax-2, Jobin-Yvon

---

---

---

---

---

---

---

---

---

---

---

---

### Front Face Detection

**Triangular Cells**

**Thin Cells & Special Compartments**

IBH, Glasgow G3 8JU  
United Kingdom

[1]

Absorbance Measurements

[1] Adapted from Gryczynski, Lubkowski, & Bucci Methods of Enz. 278: 538

---

---

---

---

---

---

---

---

---

---

---

---

### Lifetime Instrumentation

---

---

---

---

---

---

---

---

---

---

---

---

## Light Sources for Decay Acquisition: Frequency and Time Domain Measurements

### Pulsed Light Sources (frequency & pulse widths)

#### Mode-Locked Lasers

ND:YAG (76 MHz) (150 ps)  
Pumped Dye Lasers (4 MHz Cavity Dumped, 10-15 ps)  
Ti:Sapphire lasers (80 MHz, 150 fs)  
Mode-locked Argon Ion lasers

#### Directly Modulated Light Sources

Diode Lasers (short pulses in ps range, & can be modulated by synthesizer)  
LEDs (directly modulated via synthesizer, 1 ns, 20 MHz)

#### Flash Lamps

Thyratron-gated nanosecond flash lamp (PTI), 25 KHz, 1.6 ns  
Coaxial nanosecond flashlamp (IBH), 10Hz-100kHz, 0.6 ns

---

---

---

---

---

---

---

---

---

---

---

---

## Modulation of CW Light Use of a Pockel's Cell

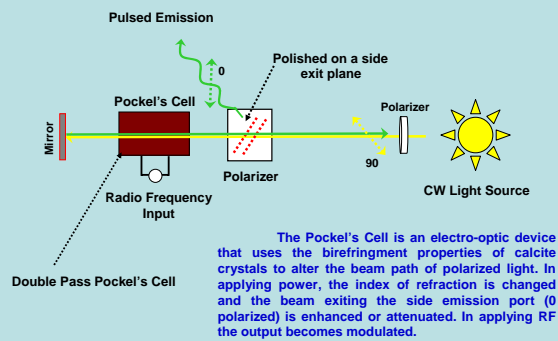

---

---

---

---

---

---

---

---

---

---

---

---

## Time Correlated Single Photon Counting

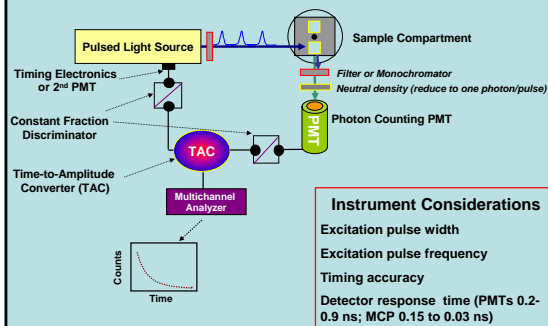

---

---

---

---

---

---

---

---

---

---

---

---

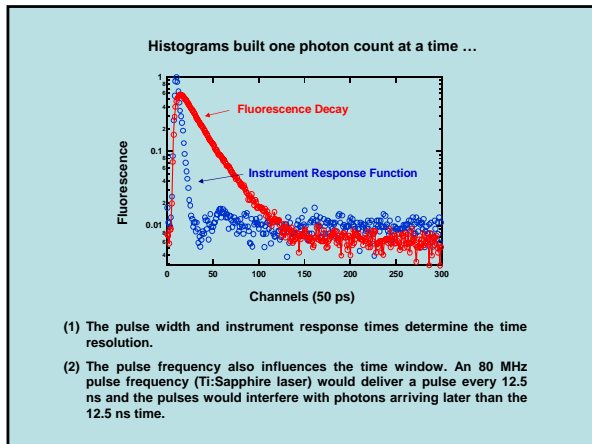

---

---

---

---

---

---

---

---

---

---

---

---

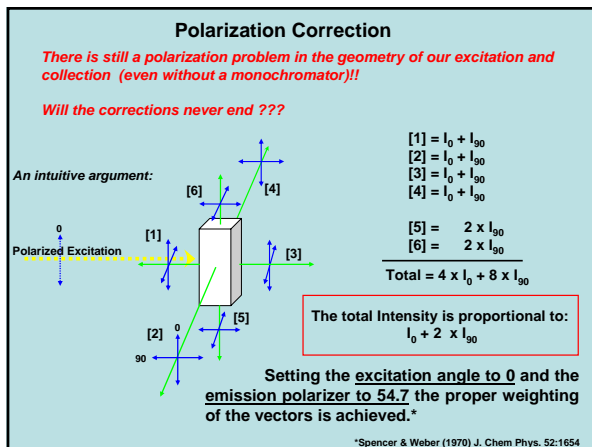

---

---

---

---

---

---

---

---

---

---

---

---

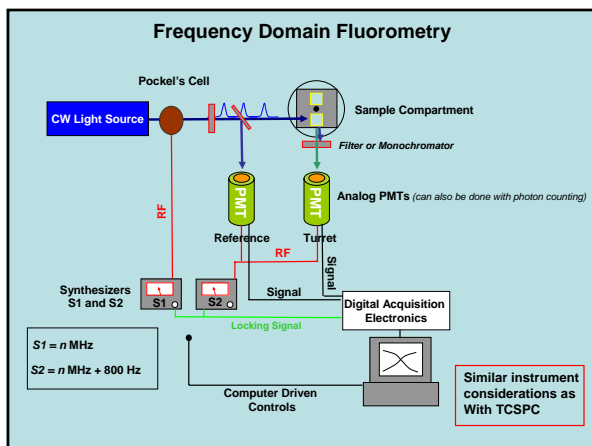

---

---

---

---

---

---

---

---

---

---

---

---

Lifetime Station #3, LDF, Champaign IL, USA



---

---

---

---

---

---

---

---